

Fisher™ ED and EAD easy-e™ Valves CL125 through CL600

Contents

Introduction	1
Scope of Manual	1
Description	2
Specifications	2
Educational Services	3
Installation	3
Maintenance	4
Packing Lubrication	5
Packing Maintenance	5
Replacing Packing	6
Trim Maintenance	10
Disassembly	10
Lapping Metal Seats	11
Valve Plug Maintenance	12
Assembly	13
Retrofit: Installing C-seal Trim	13
Replacement of Installed C-seal Trim	15
Trim Removal (C-seal Constructions)	15
Lapping Metal Seats (C-seal Constructions) ..	19
Remachining Metal Seats (C-seal Constructions)	19
Trim Replacement (C-seal Constructions) ...	19
ENVIRO-SEAL™ Bellows Seal Bonnet	20
Replacing a Plain or Extension Bonnet with an ENVIRO-SEAL Bellows Seal Bonnet (Stem/Bellows Assembly)	20
Replacement of an Installed ENVIRO-SEAL Bellows Seal Bonnet (Stem/Bellows Assembly)	23

Figure 1. Fisher ED Valve with 667 Actuator



W1916-2

Purging the ENVIRO-SEAL Bellows Seal Bonnet	24
Parts Ordering	24
Parts Kits	25
Parts List	28

Introduction

Scope of Manual

This instruction manual includes installation, maintenance, and parts information for NPS 1 through 8 Fisher ED valves, and NPS 1 through 6 EAD valves, through CL600 ratings. Refer to separate manuals for instructions covering the actuator and accessories.

Do not install, operate, or maintain ED or EAD valves without being fully trained and qualified in valve, actuator, and accessory installation, operation, and maintenance. To avoid personal injury or property damage, it is important to carefully read, understand, and follow all the contents of this manual, including all safety cautions and warnings. If you have any questions about these instructions, contact your [Emerson sales office](#) or Local Business Partner before proceeding.

Table 1. Specifications

<p>End Connection Styles</p> <p>Cast Iron Valves <i>Flanged:</i> CL125 flat-face or 250 raised-face flanges per ASME B16.1</p> <p>Steel and Stainless Steel Valves <i>Flanged:</i> CL150, 300, and 600 raised-face or ring-type joint flanges per ASME B16.5 <i>Screwed or Socket Welding:</i> All available ASME B16.11 schedules that are consistent with CL600 per ASME B16.34 <i>Buttwelding:</i> NPS 1 through 8 Schedules 40 or 80 consistent with ASME B16.25</p> <p>Maximum Inlet Pressure⁽¹⁾</p> <p>Cast Iron Valves <i>Flanged:</i> Consistent with CL125B or 250B pressure-temperature ratings per ASME B16.1</p> <p>Steel and Stainless Steel Valves <i>Flanged:</i> Consistent with CL150, 300, and 600⁽²⁾ pressure-temperature ratings per ASME B16.34 <i>Screwed or Welding:</i> Consistent with CL600 pressure-temperature ratings per ASME B16.34</p> <p>Shutoff Classifications per ANSI/FCI 70-2 and IEC 60534-4</p> <p>Standard: Class II</p>	<p>Optional: Class III--For valves with graphite piston ring and 3.4375 inch or larger port diameter; Class IV--For valves with multiple graphite piston rings and 4.375 inch or larger port diameter</p> <p>C-seal trim: High-temperature, Class V. See table 2</p> <p>Flow Characteristics</p> <p>Standard Cages: ■ Linear, ■ quick opening, or ■ equal percentage Whisper Trim™ and WhisperFlo™ Cages: Linear</p> <p>Flow Directions</p> <p>Linear, Quick Opening, or Equal Percentage Cage: Normally down Whisper Trim and WhisperFlo Cages: Always up</p> <p>Approximate Weights</p> <p>NPS 1 & 1-1/4 valves: 14 kg (30 lb) NPS 1-1/2 valves: 20 kg (45 lb) NPS 2 valves: 30 kg (67 lb) NPS 2-1/2 valves: 45 kg (100 lb) NPS 3 valves: 57 kg (125 lb) NPS 4 valves: 77 kg (170 lb) NPS 6 valves: 159 kg (350 lb) NPS 8 valves: 408 kg (900 lb)</p>
--	---

1. The pressure/temperature limits in this manual and any applicable standard or code limitation for valve should not be exceeded.

2. Certain bonnet bolting material selections may require a CL600 easy-e valve assembly to be derated. Contact your [Emerson sales office](#) or Local Business Partner.

Description

These single-port valves have cage guiding, quick-change trim, and balanced push-down-to-close valve plug action. Valve configurations are as follows:

ED--Globe-style valve (figure 1) with metal-to-metal seating for all general applications over a wide variety of pressure drops and temperatures.

EAD--Angle version of ED, used to facilitate piping or in applications where a self-draining valve is required.

C-seal trim is available for ED valves, CL150, 300, and 600, in NPS 2-1/2, 3, 4, 6, and 8. C-seal trim is available for EAD valves, CL150, 300, and 600, in NPS 3, 4, and 6.

With C-seal trim, a balanced valve can achieve high-temperature, Class V shutoff. Because the C-seal plug seal is formed from metal (N07718 nickel alloy) rather than an elastomer, a valve equipped with the C-seal trim can be applied in processes with a fluid temperature of up to 593°C (1100°F), provided other material limits are not exceeded.

Specifications

Typical specifications for these valves are shown in table 1.

Educational Services

For information on available courses for Fisher ED and EAD valves, as well as a variety of other products, contact:

Emerson Automation Solutions
Educational Services - Registration
Phone: 1-641-754-3771 or 1-800-338-8158
E-mail: education@emerson.com
emerson.com/fishervalvetraining

Installation

⚠ WARNING

Always wear protective gloves, clothing, and eyewear when performing any installation operations to avoid personal injury.

Personal injury or equipment damage caused by sudden release of pressure may result if the valve assembly is installed where service conditions could exceed the limits given in table 1 or on the appropriate nameplates. To avoid such injury or damage, provide a relief valve for over-pressure protection as required by government or accepted industry codes and good engineering practices.

Check with your process or safety engineer for any additional measures that must be taken to protect against process media.

If installing into an existing application, also refer to the WARNING at the beginning of the Maintenance section in this instruction manual.

CAUTION

When ordered, the valve configuration and construction materials were selected to meet particular pressure, temperature, pressure drop, and controlled fluid conditions. Responsibility for the safety of process media and compatibility of valve materials with process media rests solely with the purchaser and end-user. Since some body/trim material combinations are limited in their pressure drop and temperature ranges, do not apply any other conditions to the valve without first contacting your [Emerson sales office](#) or Local Business Partner.

1. Before installing the valve, inspect the valve and associated equipment for any damage and any foreign material.
2. Make certain the valve body interior is clean, that pipelines are free of foreign material, and that the valve is oriented so that pipeline flow is in the same direction as the arrow on the side of the valve.
3. The control valve assembly may be installed in any orientation unless limited by seismic criteria. However, the normal method is with the actuator vertical above the valve. Other positions may result in uneven valve plug and cage wear, and improper operation. With some valves, the actuator may also need to be supported when it is not vertical. For more information, consult your Emerson sales office or Local Business Partner.
4. Use accepted piping and welding practices when installing the valve in the line. For flanged valves, use a suitable gasket between the valve and pipeline flanges.

CAUTION

Depending on valve body materials used, post weld heat treating may be required. If so, damage to internal elastomeric and plastic parts, as well as internal metal parts is possible. Shrink-fit pieces and threaded connections may also loosen. In

general, if post weld heat treating is to be performed, all trim parts should be removed. Contact your [Emerson sales office](#) or Local Business Partner for additional information.

5. With a leak-off bonnet construction, remove the pipe plugs (keys 14 and 16, figure 18) to hook up the leak-off piping. If continuous operation is required during inspection or maintenance, install a three-valve bypass around the control valve assembly.
6. If the actuator and valve are shipped separately, refer to the actuator mounting procedure in the appropriate actuator instruction manual.

Table 2. Additional Shutoff Classification

Valve	Valve Size, NPS	Port Diameter, Inches	Cage Style	Leakage Class	
ED (CL150-600)	2-1/2	2.875	Equal Percentage, Linear, Whisper I, Cavitrol™ III, 1 stage	V (for port diameters from 2.875 through 8-inch with optional C-seal trim)	
	3	3.4375			
	3	2.875	Cavitrol III, 2 stage		
	4	2.875			
	4	4.375	Equal Percentage, Linear, Whisper I, Cavitrol III, 1 stage		
	6	6	5.375		Whisper III (A3, B3, D3, D3), Cavitrol III, 2 stage
			7		Equal Percentage, Linear, Whisper I, Cavitrol III, 1 stage
	8	8	7		Cavitrol III, 2 stage
			8		Equal Percentage, Linear, Whisper I, Cavitrol III, 1 stage

⚠ WARNING

Personal injury could result from packing leakage. Valve packing was tightened before shipment; however, the packing might require some readjustment to meet specific service conditions. Check with your process or safety engineer for any additional measures that must be taken to protect against process media.

Valves with ENVIRO-SEAL live-loaded packing or HIGH-SEAL live-loaded packing will not require this initial re-adjustment. See the Fisher instruction manuals, ENVIRO-SEAL Packing System for Sliding-Stem Valves or HIGH-SEAL Live-Loaded Packing System (as appropriate), for packing instructions. If you wish to convert your present packing arrangement to ENVIRO-SEAL packing, refer to the retrofit kits listed in the Parts Kit sub-section near the end of this manual.

Maintenance

Valve parts are subject to normal wear and must be inspected and replaced as necessary. Inspection and maintenance frequency depends on the severity of service conditions. This section includes instructions for packing lubrication, packing maintenance, trim maintenance, and ENVIRO-SEAL bellows seal bonnet replacement. All maintenance operations may be performed with the valve in the line.

⚠ WARNING

Avoid personal injury or property damage from sudden release of process pressure or bursting of parts. Before performing any maintenance operations:

- Do not remove the actuator from the valve while the valve is still pressurized.
- Always wear protective gloves, clothing, and eyewear when performing any maintenance operations to avoid personal injury.
- Disconnect any operating lines providing air pressure, electric power, or a control signal to the actuator. Be sure the actuator cannot suddenly open or close the valve.

- Use bypass valves or completely shut off the process to isolate the valve from process pressure. Relieve process pressure from both sides of the valve. Drain the process media from both sides of the valve.
 - Vent the pneumatic actuator loading pressure and relieve any actuator spring precompression.
 - Use lock-out procedures to be sure that the above measures stay in effect while you work on the equipment.
 - The valve packing box may contain process fluids that are pressurized, *even when the valve has been removed from the pipeline*. Process fluids may spray out under pressure when removing the packing hardware or packing rings, or when loosening the packing box pipe plug.
 - Check with your process or safety engineer for any additional measures that must be taken to protect against process media.
-

Note

Whenever a gasket seal is disturbed by removing or shifting gasketed parts, install a new gasket during reassembly. This ensures a good gasket seal because the used gasket may not seal properly.

Packing Lubrication

Note

ENVIRO-SEAL or HIGH-SEAL packing does not require lubrication.

⚠ WARNING

To avoid personal injury or property damage resulting from fire or explosion, do not lubricate packing used in oxygen service or in processes with temperatures over 260°C (500°F).

If a lubricator or lubricator/isolating valve (figure 2) is provided for PTFE/composition or other packings that require lubrication, it will be installed in place of the pipe plug (key 14, figure 18). Use a good quality silicon-based lubricant. Do not lubricate packing used in oxygen service or in processes with temperatures over 260°C (500°F). To operate the lubricator, simply turn the cap screw clockwise to force the lubricant into the packing box. The lubricator/isolating valve operates the same way except open the isolating valve before turning the cap screw and then close the isolating valve after lubrication is completed.

Packing Maintenance

Note

For valves with ENVIRO-SEAL packing, see the Fisher instruction manual, ENVIRO-SEAL Packing System for Sliding-Stem Valves, [D101642X012](#), for packing instructions.

For valves with HIGH-SEAL packing, see the Fisher instruction manual, HIGH-SEAL Live-Loaded Packing System, [D101453X012](#), for packing instructions.

Key numbers refer to figure 3 for PTFE V-ring packing and to figure 4 for PTFE/composition packing, unless otherwise indicated.

Figure 2. Lubricator and Lubricator/Isolating Valve (optional)

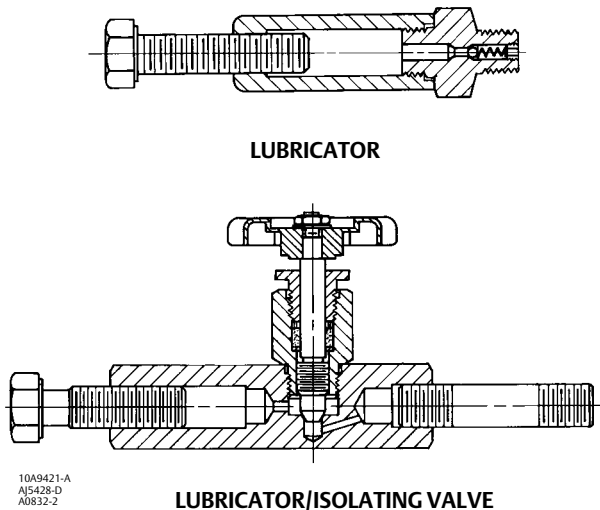

For spring-loaded single PTFE V-ring packing, the spring (key 8, figure 3) maintains a sealing force on the packing. If leakage is noted around the packing follower (key 13, figure 3), check to be sure the shoulder on the packing follower is touching the bonnet. If the shoulder is not touching the bonnet, tighten the packing flange nuts (key 5, figure 18) until the shoulder is against the bonnet. If leakage cannot be stopped in this manner, proceed to the Replacing Packing procedure.

If there is undesirable packing leakage with other than spring-loaded packing, first try to limit the leakage and establish a stem seal by tightening the packing flange nuts.

If the packing is relatively new and tight on the stem, and if tightening the packing flange nuts does not stop the leakage, the valve stem may be worn or nicked so that a seal cannot be made. The surface finish of a new valve stem is critical for making a good packing seal. If the leakage comes from the outside diameter of the packing, the leakage may be caused by nicks or scratches around the packing box wall. If performing any of the following procedures, inspect the valve stem and packing box wall for nicks and scratches.

Replacing Packing

▲ WARNING

Refer to the **WARNING** at the beginning of the Maintenance section in this instruction manual.

1. Isolate the control valve from the line pressure, release pressure from both sides of the valve body, and drain the process media from both sides of the valve. If using a power actuator, also shut off all pressure lines to the power actuator, and release all pressure from the actuator. Use lock-out procedures to be sure that the above measures stay in effect while you work on the equipment.
2. Disconnect the operating lines from the actuator and any leak-off piping from the bonnet. Disconnect the stem connector, then remove the actuator from the valve by unscrewing the yoke locknut (key 15, figure 18) or the hex nuts (key 26, figure 18).

Figure 3. PTFE V-Ring Packing Arrangements for Plain or Extension Bonnets

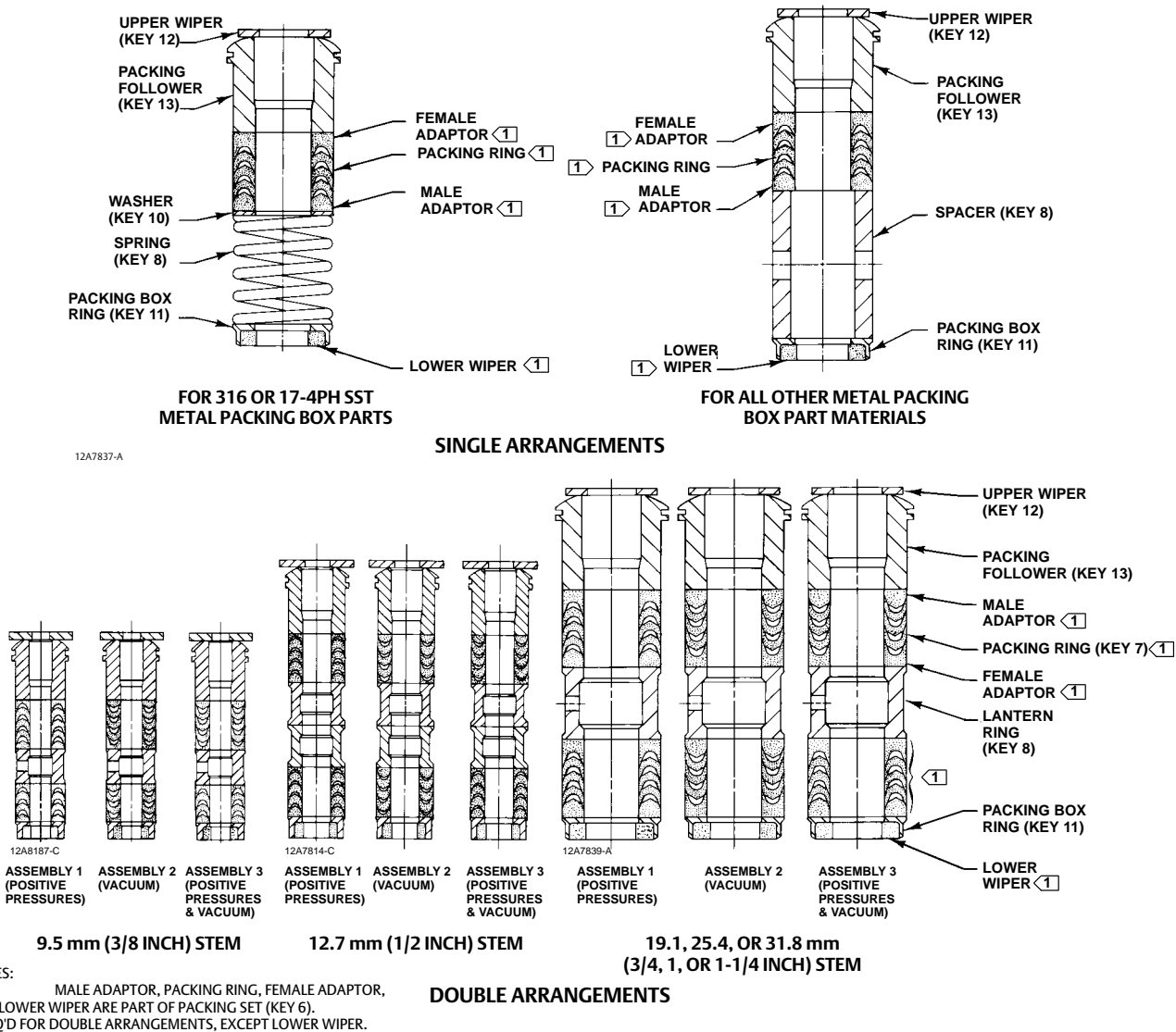

Table 3. Body-to-Bonnet Bolt Torque Guidelines

Valve Size, NPS		Bolt Torques ^(1, 3)			
ED	EAD	SA193-B7		SA193-B8M ⁽²⁾	
		N•m	Lbf•ft	N•m	Lbf•ft
1-1/4 or less	1	129	95	64	47
1-1/2, 1-1/2 x 1, 2, or 2 x 1	2 or 2 x 1	96	71	45	33
2-1/2 or 2-1/2 x 1-1/2	3 or 3 x 1-1/2	129	95	64	47
3, 3 x 2, or 3 x 2-1/2	4 or 4 x 2	169	125	88	65
4, 4 x 2-1/2, or 4 x 3	6 or 6 x 2-1/2	271	200	156	115
6	---	549	405	366	270
8	---	746	550	529	390

1. Determined from laboratory tests.
 2. SA193-B8M annealed.
 3. For other materials, contact your [Emerson sales office](#) or Local Business Partner for torque values.

3. Loosen the packing flange nuts (key 5, figure 18) so that the packing is not tight on the valve stem. Remove any travel indicator parts and stem locknuts from the valve stem threads.

⚠ WARNING

To avoid personal injury or property damage caused by uncontrolled movement of the bonnet, loosen the bonnet by following the instructions in the next step. Do not remove a stuck bonnet by pulling on it with equipment that can stretch or store energy in any other manner. The sudden release of stored energy can cause uncontrolled movement of the bonnet.

Note

The following step also provides additional assurance that the valve body fluid pressure has been relieved.

CAUTION

Avoid damaging the seating surface caused by the valve plug and stem assembly dropping from the bonnet (key 1, figure 18) after being lifted part way out. When lifting the bonnet, temporarily install a valve stem locknut on the valve stem. This locknut will prevent the valve plug and stem assembly from dropping out of the bonnet.

If the cage starts to lift with the bonnet, tap it with a plastic mallet, or other soft material, to be sure it stays in the valve.

4. Hex nuts (key 16, figure 19, 20, or 21) or cap screws (not shown) attach the bonnet (key 1, figure 18) to the valve body (key 1, figure 19, 20, or 21). Loosen these nuts or cap screws approximately 3 mm (1/8 inch). Then loosen the body-to-bonnet gasketed joint by either rocking the bonnet or prying between the bonnet and valve. Work the prying tool around the bonnet until the bonnet loosens. If no fluid leaks from the joint, remove the nuts or cap screws completely and carefully lift the bonnet off the valve.
5. Remove the locknut and separate the valve plug and stem from the bonnet. Set the parts on a protective surface to prevent damage to gasket or seating surfaces.
6. Remove the bonnet gasket (key 10, figure 19, 20, or 21) and cover the opening in the valve to protect the gasket surface and prevent foreign material from getting into the valve body cavity.
7. Remove the packing flange nuts, packing flange, upper wiper, and packing follower (keys 5, 3, 12, and 13, figure 18). Carefully push out all the remaining packing parts from the valve side of the bonnet using a rounded rod or other tool that will not scratch the packing box wall. Clean the packing box and the metal packing parts.
8. Inspect the valve stem threads and packing box surfaces for any sharp edges which might cut the packing. Scratches or burrs could cause packing box leakage or damage to the new packing. If the surface condition cannot be improved by light sanding, replace the damaged parts by following the appropriate steps in the Trim Maintenance procedure.
9. Remove the cover protecting the valve body cavity and install a new bonnet gasket (key 10, figure 19 through 21), making sure the gasket seating surfaces are clean and smooth. Place the valve plug and stem into the valve body, making sure it is properly centered on the seat ring. Then slide the bonnet over the stem and onto the stud bolts (key 16, figure 19, 20, or 21) or onto the valve body cavity if cap screws (not shown) will be used instead.

Figure 4. PTFE/Composition Packing Arrangements for Plain or Extension Bonnets

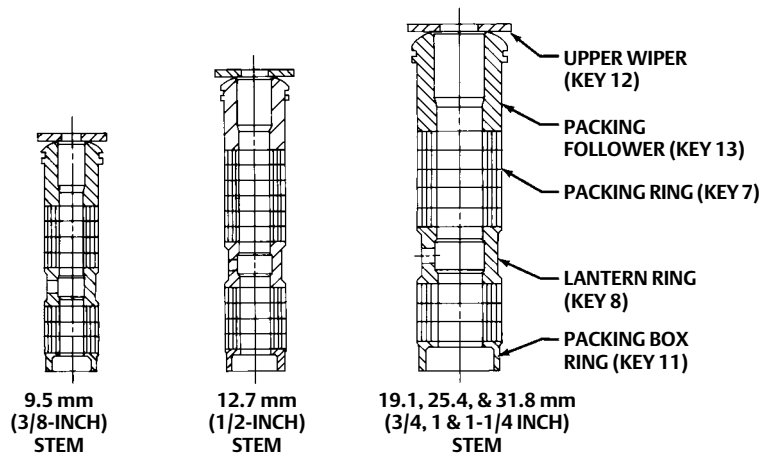

9.5 mm
(3/8-INCH)
STEM

12.7 mm
(1/2-INCH)
STEM

19.1, 25.4, & 31.8 mm
(3/4, 1 & 1-1/4 INCH)
STEM

12A8088-A
12A7815-A
12A8173-A
A5904

TYPICAL (DOUBLE) ARRANGEMENT

Note

Proper performance of the bolting procedures in step 10 compresses the spiral wound gasket (key 12, figure 19 or 20) or load ring (key 26, figure 21) enough to both load and seal the seat ring gasket (key 13, figure 19, 20, or 21). It also compresses the outer edge of the bonnet gasket (key 10, figure 19 through 21) enough to seal the body-to-bonnet joint.

The bolting procedures in step 10 include--but are not limited to--ensuring that bolting threads are clean, and evenly tightening the cap screws, or the nuts onto the studs, in a crisscross pattern. Tightening one cap screw or nut may loosen an adjacent cap screw or nut. Repeat the crisscross tightening pattern several times until each cap screw or nut is tight and the body-to-bonnet seal is made. When the operating temperature has been reached, perform the torquing procedure once again.

10. Install bolting, using accepted bolting procedures during tightening, so that the body-to-bonnet joint will withstand test pressures and application service conditions. Use the bolt torques in table 3 as guidelines.
11. Install new packing and the metal packing box parts according to the appropriate arrangement in figure 3, 4, or 5. Place a smooth-edged pipe over the valve stem and gently tap each soft packing part into the packing box.
12. Slide the packing follower, upper wiper, and packing flange (keys 13, 12, and 3, figure 18) into position. Lubricate the packing flange studs (key 4, figure 18) and the faces of the packing flange nuts (key 5, figure 18). Install the packing flange nuts.
13. For spring-loaded PTFE V-ring packing, tighten the packing flange nuts until the shoulder on the packing follower (key 13, figure 18) contacts the bonnet.

For graphite packing, tighten the packing flange nuts to the maximum recommended torque shown in table 4. Then, loosen the packing flange nuts, and retighten them to the recommended minimum torque shown in table 4.

For other packing types, tighten the packing flange nuts alternately in small equal increments until one of the nuts reaches the minimum recommended torque shown in table 4. Then, tighten the remaining flange nut until the packing flange is level and at a 90-degree angle to the valve stem.

For ENVIRO-SEAL or HIGH-SEAL live-loaded packing, refer to the note at the beginning of Packing Maintenance.

14. Mount the actuator on the valve assembly and reconnect the actuator and valve stem according to the procedure in the appropriate actuator instruction manual.

Figure 5. Graphite Ribbon/Filament Packing for Plain or Extension Bonnets

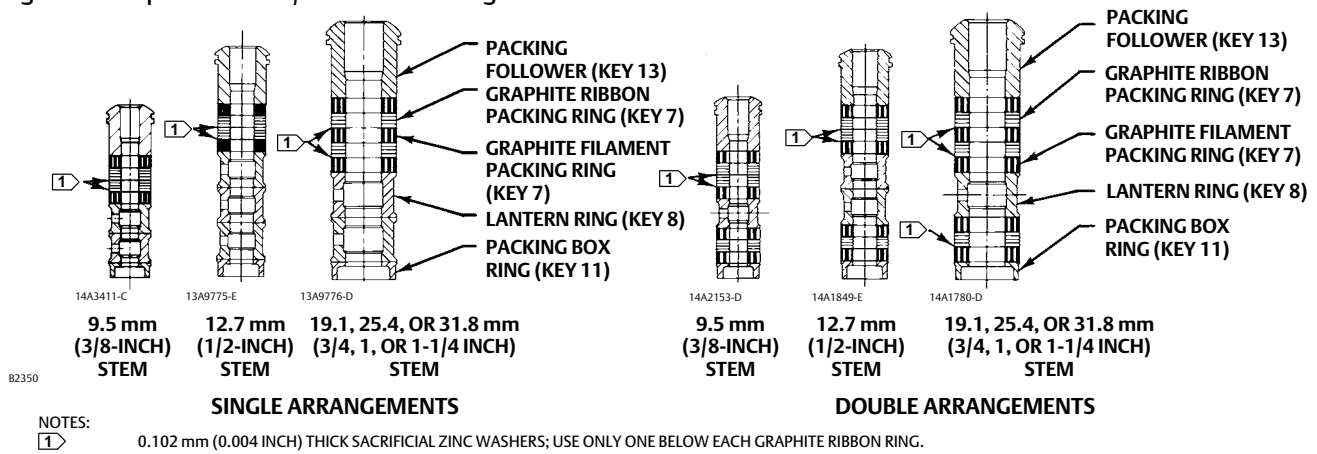

Trim Maintenance

⚠ WARNING

Observe the warning at the start of the Maintenance section.

For C-seal construction, see the appropriate C-seal sections in this instruction manual.

Except where indicated, key numbers in this section are referenced in figure 19 for standard NPS 1 through 6 constructions, figure 20 for Whisper Trim III cage detail, figure 21 for the NPS 8 ED valve, and figures 22 and 23 for WhisperFlo trim. Some valve plug constructions require three piston rings (key 6).

Disassembly

1. Remove the actuator and the bonnet according to steps 1 through 5 of the Replacing Packing procedure in the Maintenance section.

⚠ WARNING

Avoid personal injury or property damage from valve or packing leakage.

The graphite piston rings in an ED or EAD valve are brittle and in two pieces. Use care to avoid damage to the piston rings caused by dropping or rough handling.

Any damage to the gasket sealing surfaces could cause the valve to leak. The surface finish of the valve stem (key 7) is critical for making a good packing seal. The inside surface of the cage or cage/baffle assembly (key 3), or cage retainer (key 31), is critical for smooth operation of the valve plug and for making a seal with the piston rings (key 6). The seating surfaces of the valve plug (key 2) and seat ring (key 9) are critical for proper shutoff. Protect these parts accordingly while disassembling the trim.

2. Remove the packing flange nuts, packing flange, upper wiper, and packing follower (keys 5, 3, 12, and 13, figure 18). Carefully push out all the remaining packing parts from the valve side of the bonnet using a rounded rod or other tool that will not scratch the packing box wall. Clean the packing box and the metal packing parts.
3. Inspect the valve stem threads and packing box surfaces for any sharp edges which might cut the packing. Scratches or burrs could cause packing box leakage or damage to the new packing. If the surface condition cannot be improved by light sanding, replace the damaged parts.

Table 4. Recommended Torque for Packing Flange Nuts

VALVE STEM DIAMETER		PRESSURE RATING	GRAPHITE TYPE PACKING				PTFE TYPE PACKING			
			Minimum Torque		Maximum Torque		Minimum Torque		Maximum Torque	
mm	Inches		N•m	Lbf•in	N•m	Lbf•in	N•m	Lbf•in	N•m	Lbf•in
9.5	3/8	CL125, 150	3	27	5	40	1	13	2	19
		CL250, 300	4	36	6	53	2	17	3	26
		CL600	6	49	8	73	3	23	4	35
12.7	1/2	CL125, 150	5	44	8	66	2	21	4	31
		CL250, 300	7	59	10	88	3	28	5	42
		CL600	9	81	14	122	4	39	7	58
19.1	3/4	CL125, 150	11	99	17	149	5	47	8	70
		CL250, 300	15	133	23	199	7	64	11	95
		CL600	21	182	31	274	10	87	15	131
25.4	1	CL300	26	226	38	339	12	108	18	162
		CL600	35	310	53	466	17	149	25	223
31.8	1-1/4	CL300	36	318	54	477	17	152	26	228
		CL600	49	437	74	655	24	209	36	314

- Remove the load ring (key 26) from an NPS 8 ED valve, or the cage adaptor (key 4) from any restricted-trim valve through NPS 4, and wrap it for protection.
- On an NPS 6 ED valve with a Whisper Trim III cage or WhisperFlo trim, remove the bonnet spacer (key 32) and bonnet gasket (key 10) on top of the spacer. Then on any construction with a cage retainer (key 31), remove the cage retainer and its associated gaskets. A Whisper Trim III and WhisperFlo cage retainer has two 3/8 inch-16 UNC tappings in which screws or bolts can be installed for lifting.
- Remove the cage or cage/baffle assembly (key 3) and the associated gaskets (keys 10, 11, and 12), and shim (key 51 for the ED valve, key 27 for the EAD valve). If the cage is stuck in the valve, use a rubber mallet to strike the exposed portion of the cage at several points around its circumference.
- Remove the seat ring or liner (key 9), seat ring gasket (key 13), and the seat ring adaptor (key 5) and adaptor gasket (key 14) where used in a restricted-trim seat ring construction.
- Inspect parts for wear or damage which would prevent proper operation of the valve. Replace or repair trim parts according to the following procedure for Lapping Metal Seats or other valve plug maintenance procedures as appropriate.

Lapping Metal Seats

CAUTION

To avoid damaging the ENVIRO-SEAL bellows seal bonnet assembly, do not attempt to lap the metal seating surfaces. The design of the assembly prevents rotation of the stem and any forced lapping rotation will damage internal components of the ENVIRO-SEAL Bellows Seal bonnet.

With metal-seat constructions, seating surfaces of the valve plug and seat ring or liner (keys 2 and 9, figure 19, 20, or 21) can be lapped for improved shutoff. (Deep nicks should be machined out rather than ground out.) Use a good quality lapping compound of a mixture of 280 to 600-grit. Apply compound to the bottom of the valve plug.

Assemble the valve to the extent that the cage and the cage retainer and bonnet spacer (if used) are in place and the bonnet is bolted to the valve. A simple handle can be made from a piece of strap iron locked to the valve plug stem with nuts. Rotate the handle alternately in each direction to lap the seats. After lapping, remove the bonnet and clean the seat surfaces. Completely assemble as described in the Assembly portion of the Trim Maintenance procedure and test the valve for shutoff. Repeat the lapping procedure if leakage is still excessive.

Valve Plug Maintenance

Except where indicated, key numbers in this section are referenced in figure 19 for standard NPS 1 through 6 constructions, figure 20 for Whisper Trim III detail, figure 21 for the NPS 8 ED valve, and figures 22 and 23 for WhisperFlo trim. Some valve plug constructions require three piston rings (key 6).

CAUTION

To avoid the piston ring (key 6) not sealing properly, be careful not to scratch the surfaces of the ring groove in the valve plug or any of the surfaces of the replacement ring.

1. With the valve plug (key 2) removed according to the Disassembly portion of the Trim Maintenance procedure, proceed as appropriate:

For the carbon-filled PTFE piston ring, The ring is split in one place. If there is visible damage, spread the ring slightly and remove it from the groove in the valve plug.

To install a carbon-filled PTFE piston ring, Spread the ring apart slightly at the split and install it over the stem and into the groove in the valve plug. The open side must face along the stem, depending on flow directions, as shown in view A of figure 19.

For the graphite piston ring, The ring can be easily removed since it is in two pieces. A new graphite piston ring is furnished as a complete ring. Use a vise with smooth or taped jaws to break this replacement ring into halves. Place the new ring in the vise so that the jaws will compress the ring into an oval. Slowly compress the ring until it snaps on both sides. If one side snaps first, do not try to tear or cut the other side. Instead, keep compressing the ring until the other side snaps. Be sure to match the broken ends when installing the ring in the valve plug groove.

CAUTION

Never reuse an old stem or adaptor with a new valve plug. Using an old stem or adaptor with a new plug requires drilling a new pin hole in the stem (or adaptor in case an ENVIRO-SEAL bellows seal bonnet is being used). This drilling weakens the stem or adaptor and may cause failure in service. However, a used valve plug may be reused with a new stem or adaptor.

Note

For plain bonnets and style 1 extension bonnets, the valve plug (key 2), valve stem (key 7), and pin (key 8) are available completely assembled. Refer to the Key 2, 7, and 8 Valve Plug and Stem Assembly tables in the Parts List.

2. To replace the valve stem (key 7), drive out the pin (key 8). Unscrew the valve plug from the stem or adaptor.
3. To replace the adaptor (key 24, figure 18) on ENVIRO-SEAL bellows seal bonnets, place the plug stem assembly and valve plug in a soft-jaw chuck or other type of vise so that the jaws grip a portion of the valve plug that is not a seating surface. Drive out the pin (key 36, figure 18). Reverse the plug stem assembly and valve plug in the soft-jaw chuck or vise. Grip the flat areas on the valve stem just below the threads for the actuator/stem connection. Unscrew the valve plug/adaptor assembly (key 24, figure 18) from the valve stem assembly (key 20, figure 18).
4. Screw the new stem or adaptor into the valve plug. Tighten to the torque value given in table 5. Refer to table 5 to select the proper drill size. Drill through the stem or adaptor, using the hole in the valve plug as a guide. Remove any chips or burrs and drive in a new pin to lock the assembly.
5. For ENVIRO-SEAL bellows seal bonnets, grip the flats of the stem extending out of the top of the bellows shroud with a soft-jaw chuck or other type of vise. Screw the valve plug/adaptor assembly onto the valve stem. Tighten as

necessary to align the pin hole in the stem with one of the holes in the adaptor. Secure the adaptor to the stem with a new pin.

Assembly

Except where indicated, key numbers are referenced in figure 19 for standard NPS 1 through 6 constructions, figure 20 for Whisper Trim III detail, figure 21 for the NPS 8 ED valve, and figures 22 and 23 for WhisperFlo trim.

Table 5. Valve Stem Connection Torque and Pin Replacement

VALVE STEM CONNECTION (VSC)		TORQUE, MINIMUM TO MAXIMUM		DRILL SIZE, INCH
mm	Inch	N•m	Lbf•ft	
9.5	3/8	40 to 47	25 to 35	3/32
12.7	1/2	81 to 115	60 to 85	1/8
19.1	3/4	237 to 339	175 to 250	3/16
25.4	1	420 to 481	310 to 355	1/4
31.8	1-1/4	827 to 908	610 to 670	1/4

1. With a restricted-trim seat ring construction, install the adaptor gasket (key 14) and seat ring adaptor (key 5).
2. Install the seat ring gasket (key 13), seat ring or liner (key 9).
3. Install the cage or cage/baffle assembly (key 3). Any rotational orientation of the cage or assembly with respect to the valve is acceptable. A Whisper Trim III cage designated by level A3, B3, or C3 may be installed with either end up. The level D3 cage/baffle assembly, however, must be installed with the hole pattern end next to the seat ring. If a cage retainer (key 31) is to be used, place it on top of the cage.
4. Slide the valve plug (key 2) and stem assembly, or valve plug and ENVIRO-SEAL bellows seal assembly, into the cage until the piston ring(s) is level with the top of the cage (key 3) or cage retainer (key 31).
5. Installing piston rings (key 6):
 - a. For valve plugs with a single piston ring: Make sure the piston ring is evenly engaged into the entrance chamfer at the top of the cage or cage retainer ring. Carefully press the piston ring into the cage or cage retainer ring.
 - b. For valve plugs with multiple piston rings: As each piston ring is slid into the cage, make sure the ring is evenly engaged in the entrance chamfer at the top of the cage or cage retainer. Also, make sure to offset the fracture in the rings to minimize leakage. Carefully press each piston ring into the cage or cage retainer ring.
6. Place the gaskets (keys 12, 11 or 14 if used, and 10) and the shim (key 27 or 51) if used, on top of the cage or cage retainer. If there is a cage adaptor (key 4) or a bonnet spacer (key 32), set it on the cage or cage retainer gaskets and place another flat sheet gasket (key 10) on top of the adaptor or spacer. If there is only a cage retainer, place another flat sheet gasket on the retainer.
7. With an NPS 8 ED valve, install the load ring (key 26).
8. Mount the bonnet on the valve and complete assembly according to steps 10 through 14 of the Replacing Packing procedure. Be sure to observe the note prior to step 10.

Retrofit: Installing C-seal Trim

Note

Additional actuator thrust is required for a valve with C-seal trim. When installing C-seal trim in an existing valve, contact your [Emerson sales office](#) or Local Business Partner for assistance in determining new actuator thrust requirements.

Assemble the new valve plug/retainer assembly (with C-seal plug seal) using the following instructions:

CAUTION

To avoid leakage when the valve is returned to service, use appropriate methods and materials to protect all sealing surfaces of the new trim parts while assembling the individual parts and during installation in the valve body.

1. Apply a suitable high-temperature lubricant to the inside diameter of the C-seal plug seal. Also, lubricate the outside diameter of the valve plug where the C-seal plug seal must be pressed into the proper sealing position (figure 6).
2. Orient the C-seal plug seal for correct sealing action based on the process fluid flow direction through the valve.
 - The open interior of the C-seal plug seal must face up in a valve with flow-up construction (figure 6).
 - The open interior of the C-seal plug seal must face down in a valve with flow-down construction (figure 6).

Figure 6. Fisher ED with C-seal Trim

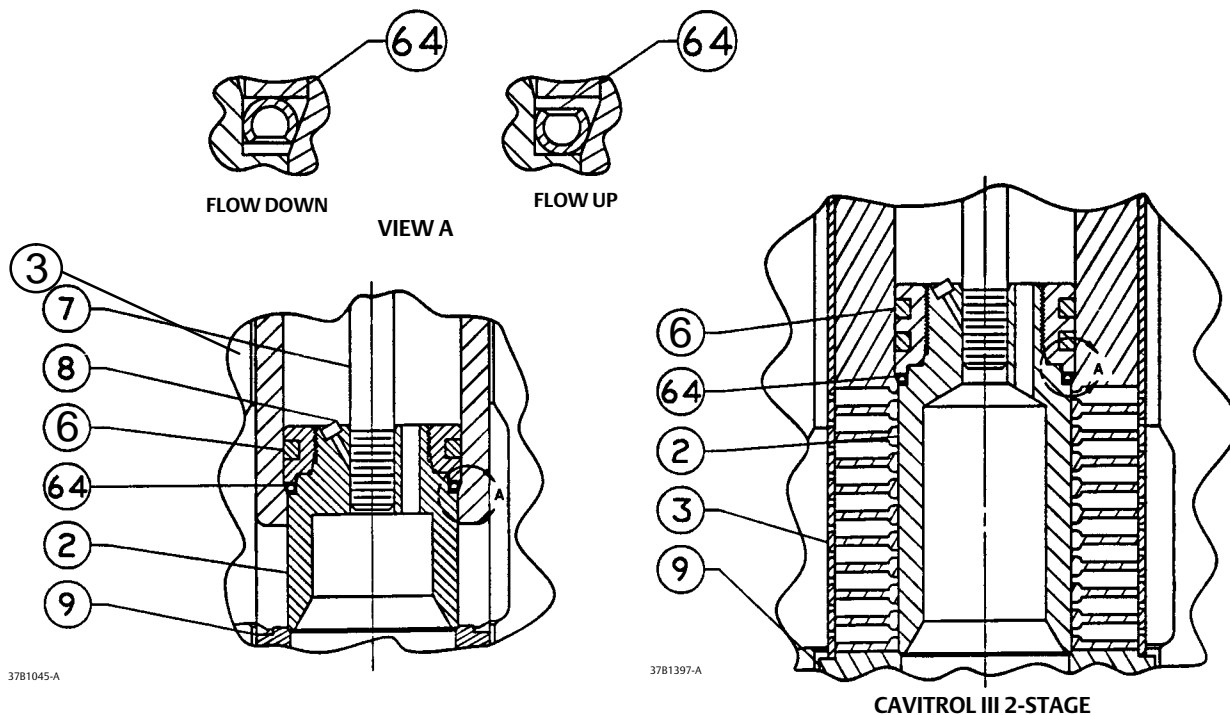

Note

An installation tool must be used to properly position the C-seal plug seal on the valve plug. A tool is available as a Fisher spare part or a tool could be manufactured following the dimensions given in figure 7.

3. Place the C-seal plug seal over the top of the valve plug and press the C-seal plug seal onto the plug using the C-seal installation tool. Carefully press the C-seal plug seal onto the plug until the installation tool contacts the horizontal reference surface of the valve plug (figure 8).
4. Apply a suitable high-temperature lubricant to the threads on the plug. Then, place the C-seal retainer onto the plug and tighten the retainer using an appropriate tool such as a strap wrench.

5. Using an appropriate tool such as a center punch, stake the threads on top of the plug in one place (figure 9) to secure the C-seal retainer.
6. Install the new plug/retainer assembly with C-seal plug seal on the new stem following the appropriate instructions in the Trim Replacement section of this manual.
7. Install piston rings by following instructions in the Trim Replacement section of this manual.
8. Remove the existing valve actuator and bonnet following the appropriate instructions in the Replacing Packing section of this manual.

CAUTION

Do not remove the existing valve stem from the valve plug unless you are planning to replace the valve stem.

Never reuse an old valve stem with a new plug or reinstall a valve stem after it has been removed. Replacing a valve stem requires drilling a new pin hole in the stem. This drilling weakens the stem and may cause failure in service. However, a used valve plug may be reused with a new valve stem.

9. Remove the existing valve stem and plug, cage, and seat ring from the valve body following the appropriate instructions in the Trim Removal section of this manual.
10. Replace all gaskets according to appropriate instructions in the Trim Replacement section of this manual.
11. Install the new seat ring, cage, valve plug/retainer assembly, and stem into the valve body and completely reassemble the valve package following the appropriate instructions in the Trim Replacement section of this manual.

CAUTION

To avoid excessive leakage and seat erosion, the valve plug must be initially seated with sufficient force to overcome the resistance of the C-seal plug seal and contact the seat ring. You can correctly seat the valve plug by applying the full actuator load. This force will adequately drive the valve plug to the seat ring, thus giving the C-seal plug seal a predetermined permanent set. Once this is done, the plug/retainer assembly, the cage, and the seat ring become a matched set.

With full actuator force applied and the valve plug fully seated, align the actuator travel indicator scale with the lower end of valve travel. Refer to the appropriate actuator instruction manual for information on this procedure.

Replacement of Installed C-seal Trim

Trim Removal (C-seal Constructions)

1. Remove the valve actuator and bonnet following the appropriate instructions in the Replacing Packing section of this manual.

CAUTION

To avoid leakage when the valve is returned to service, use appropriate methods and materials to protect all sealing surfaces of the trim parts during maintenance.

Use caution when removing piston ring(s) and C-seal plug seal to avoid scratching any sealing surface.

FOR VALVE PLUGS FITTING PORT SIZE (Inches)	DIMENSIONS, mm (See Drawing Below)								Part Number (To Order A Tool)
	A	B	C	D	E	F	G	H	
2.875	82.55	52.324 - 52.578	4.978 - 5.029	3.708 - 3.759	41.148	52.680 - 52.781	55.118 - 55.626	70.891 - 71.044	24B9816X012
3.4375	101.6	58.674 - 58.928	4.978 - 5.029	3.708 - 3.759	50.8	61.011 - 61.112	63.449 - 63.957	85.166 - 85.319	24B5612X012
3.625	104.394	65.024 - 65.278	4.978 - 5.029	3.708 - 3.759	50.8	68.936 - 69.037	71.374 - 71.882	89.941 - 90.094	24B3630X012
4.375	125.984	83.439 - 83.693	4.978 - 5.029	3.708 - 3.759	50.8	87.351 - 87.452	89.789 - 90.297	108.991 - 109.144	24B3635X012
5.375	142.748	100.076 - 100.33	4.978 - 5.029	3.708 - 3.759	45.974	103.835 - 103.937	106.274 - 106.782	128.219 - 128.372	23B9193X012
7	184.15	141.376 - 141.630	4.978 - 5.029	3.708 - 3.759	60.198	145.136 - 145.237	147.574 - 148.082	169.520 - 169.672	23B9180X012
8	209.55	166.776 - 167.030	4.978 - 5.029	3.708 - 3.759	55.88	170.536 - 170.637	172.974 - 173.482	194.920 - 195.072	24B9856X012
FOR VALVE PLUGS FITTING PORT SIZE (Inches)	DIMENSIONS, INCHES (See Drawing Below)								Part Number (To Order A Tool)
	A	B	C	D	E	F	G	H	
2.875	3.25	2.060 - 2.070	0.196 - 0.198	0.146 - 0.148	1.62	2.074 - 2.078	2.170 - 2.190	2.791 - 2.797	24B9816X012
3.4375	4.00	2.310 - 2.320	0.196 - 0.198	0.146 - 0.148	2.00	2.402 - 2.406	2.498 - 2.518	3.353 - 3.359	24B5612X012
3.625	4.11	2.560 - 2.570	0.196 - 0.198	0.146 - 0.148	2.00	2.714 - 2.718	2.810 - 2.830	3.541 - 3.547	24B3630X012
4.375	4.96	3.285 - 3.295	0.196 - 0.198	0.146 - 0.148	2.00	3.439 - 3.443	3.535 - 3.555	4.291 - 4.297	24B3635X012
5.375	5.62	3.940 - 3.950	0.196 - 0.198	0.146 - 0.148	1.81	4.088 - 4.092	4.184 - 4.204	5.048 - 5.054	23B9193X012
7	7.25	5.566 - 5.576	0.196 - 0.198	0.146 - 0.148	2.37	5.714 - 5.718	5.810 - 5.830	6.674 - 6.680	23B9180X012
8	8.25	6.566 - 6.576	0.196 - 0.198	0.146 - 0.148	2.20	6.714 - 6.718	6.810 - 6.830	7.674 - 7.680	24B9856X012

Figure 7. C-seal Plug Seal Installation Tool

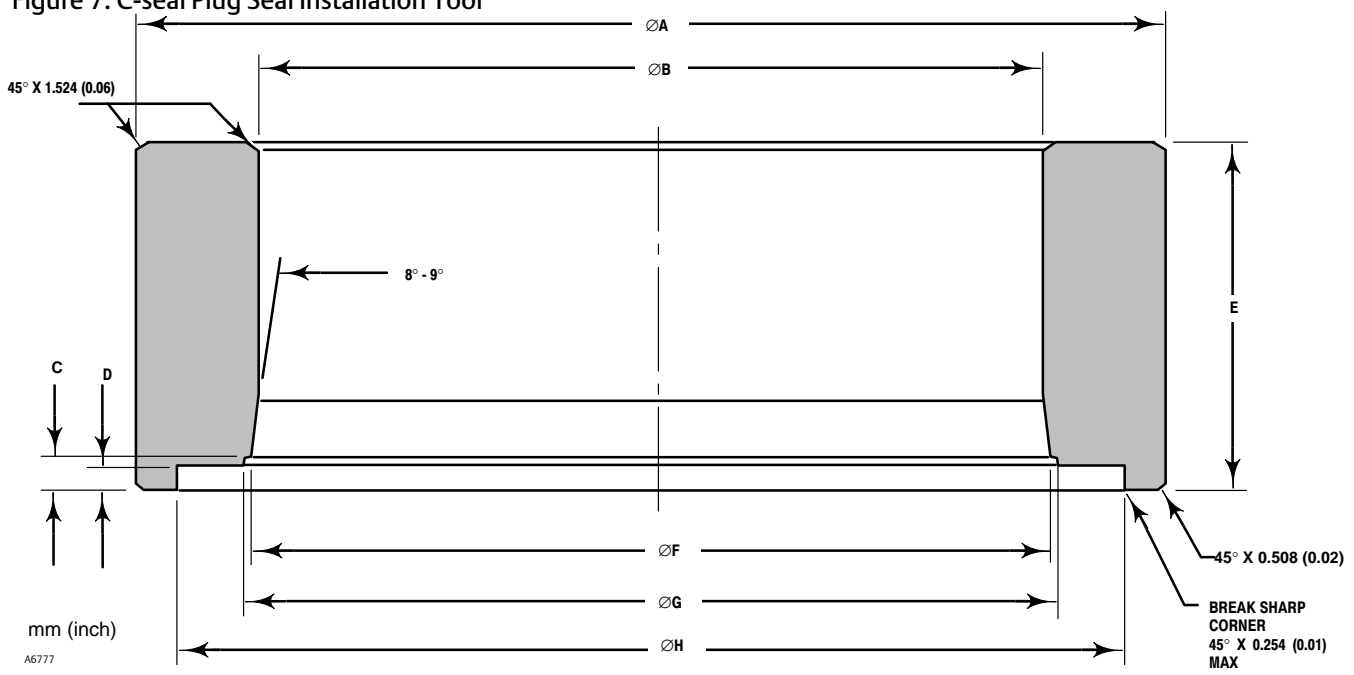
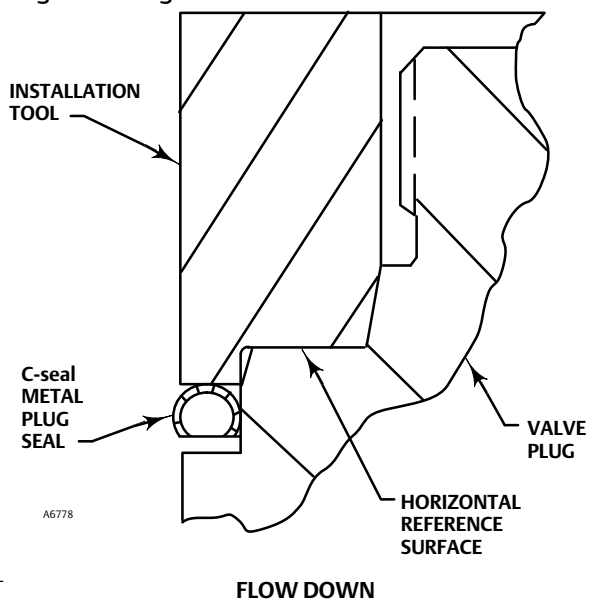
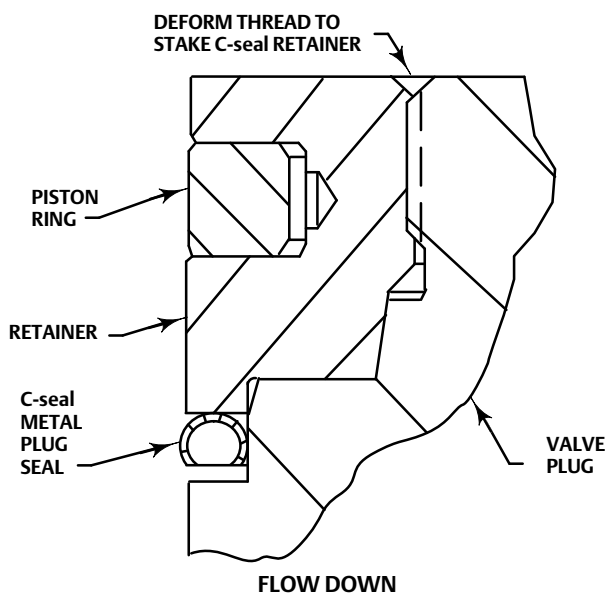

Figure 8. Installing the C-seal Plug Seal Using the Installation Tool



NOTE:
PRESS INSTALLATION TOOL OVER VALVE PLUG
UNTIL THE TOOL CONTACTS THE HORIZONTAL
REFERENCE SURFACE OF THE VALVE PLUG.

Figure 9. Stake the Threads of the C-seal Retainer



CAUTION

Do not remove the valve stem from the plug/retainer assembly unless you are planning to replace the valve stem. Never reuse an old valve stem with a new plug or reinstall a valve stem after it has been removed. Replacing a valve stem requires drilling a new pin hole in the stem. This drilling weakens the stem and may cause failure in service. However, a used valve plug may be reused with a new valve stem.

Figure 10. Lower (Valve Plug to Seat Ring) and Upper (C-seal Plug Seal to Cage) Seating Surfaces

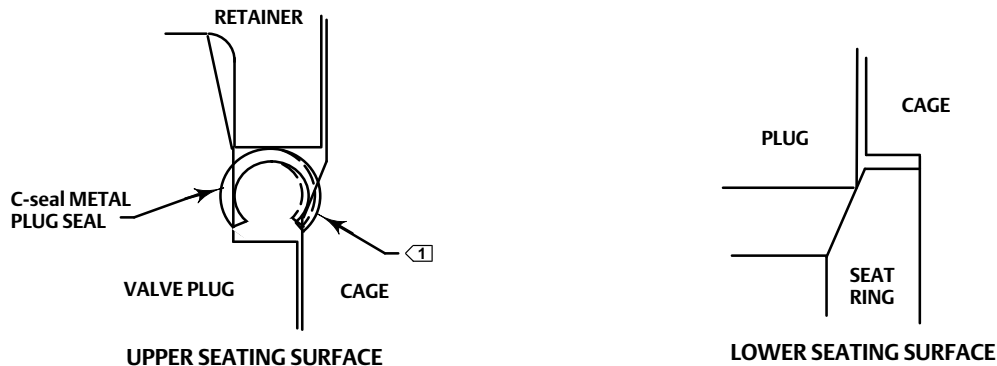

A6780

NOTE:

① UPPER SEATING SURFACE IS THE AREA OF CONTACT BETWEEN THE C-seal METAL PLUG SEAL AND THE CAGE.

Figure 11. Example of Machining the Lower (Valve Plug to Seat Ring) and Upper (C-seal Plug Seal to Cage) Seating Surfaces

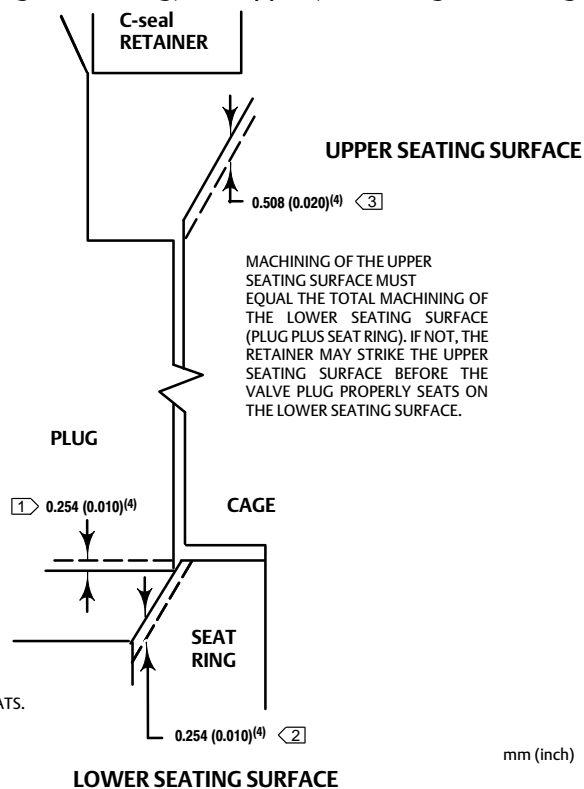

NOTE:

- ① REMOVAL OF 0.254 mm (0.010 inch) FROM THE VALVE PLUG
PLUS ② REMOVAL OF 0.254 mm (0.010 inch) FROM THE SEAT RING
MUST EQUAL ③ REMOVAL OF 0.508 mm (0.020 inch) FROM THE
UPPER SEATING SURFACE IN THE CAGE
4. THESE VALUES ARE FOR EXAMPLE ONLY. REMOVE ONLY THE
MINIMUM AMOUNT OF MATERIAL REQUIRED TO REFURBISH THE SEATS.

A6781 / IL

mm (inch)

2. Remove the plug/retainer assembly (with C-seal plug seal), cage, and seat ring from the valve body following the appropriate instructions in the Trim Removal section of this manual.
3. Locate the staked thread on top of the valve plug (figure 9). The staked thread secures the retainer. Use a drill with a 1/8 inch bit to drill out the staked area of the thread. Drill approximately 3 mm (1/8 inch) into the metal to remove the staking.
4. Locate the break between sections of the piston ring(s). Using an appropriate tool such as a flat-blade screwdriver, carefully pry out the piston ring(s) from the groove(s) in the C-seal retainer.

5. After removing the piston ring(s), locate the 1/4-inch diameter hole in the groove. In a retainer with two piston ring grooves, the hole will be found in the upper groove.
6. Select an appropriate tool such as a punch and place the tip of the tool into the hole with the body of the tool held tangent to the outside diameter of the retainer. Strike the tool with a hammer to rotate the retainer and free it from the valve plug. Remove the retainer from the plug.
7. Use an appropriate tool such as a flat-blade screwdriver to pry the C-seal plug seal off the plug. Use caution to avoid scratches or other damage to the sealing surfaces where the C-seal plug seal makes contact with the valve plug (figure 10).
8. Inspect the lower seating surface where the valve plug contacts the seat ring for wear or damage which would prevent proper operation of the valve. Also, inspect the upper seating surface inside the cage where the C-seal plug seal contacts the cage, and inspect the sealing surface where the C-seal plug seal makes contact with the plug (figure 10).
9. Replace or repair trim parts according to the following procedure for Lapping Metal Seats, Remachining Metal Seats, or other valve plug maintenance procedures as appropriate.

Lapping Metal Seats (C-seal Constructions)

Before installing a new C-seal plug seal, lap the lower seating surface (valve plug to seat ring, figure 10) following appropriate procedures in the Lapping Metal Seats section of this manual.

Remachining Metal Seats (C-seal Constructions)

See figure 11. A valve plug with a C-seal metal plug seal features two seating surfaces. One seating surface is found where the valve plug contacts the seat ring. The second seating surface is found where the C-seal plug seal contacts the upper seating surface in the cage. If you machine the seats on the seat ring and/or plug, you must machine an equal dimension from the seating area in the cage.

CAUTION

If metal is removed from the seat ring and plug and a corresponding amount is not removed from the cage seating area, the C-seal plug seal will be crushed as the valve closes and the C-seal retainer will strike the seating area of the cage, preventing the valve from closing.

Trim Replacement (C-seal Constructions)

1. Apply a suitable high-temperature lubricant to the inside diameter of the C-seal plug seal. Also, lubricate the outside diameter of the valve plug where the C-seal plug seal must be pressed into the proper sealing position (figure 6).
2. Orient the C-seal plug seal for correct sealing action based on the process fluid flow direction through the valve.
 - The open interior of the C-seal plug seal must face up in a valve with flow-up construction (figure 6).
 - The open interior of the C-seal plug seal must face down in a valve with flow-down construction (figure 6).

Note

An installation tool must be used to properly position the C-seal plug seal on the valve plug. A tool is available as a Fisher spare part or a tool could be manufactured following the dimensions given in figure 7.

3. Place the C-seal plug seal over the top of the valve plug and press it onto the plug using the installation tool. Carefully press the C-seal plug seal onto the plug until the installation tool contacts the horizontal reference surface of the valve plug (figure 8).

4. Apply a suitable high-temperature lubricant to the threads on the plug. Then, place the C-seal retainer onto the plug and tighten the retainer using an appropriate tool such as a strap wrench.
5. Using an appropriate tool such as a center punch, stake the threads on top of the plug in one place (figure 9) to secure the C-seal retainer.
6. Replace the piston ring(s) following instructions in the Trim Replacement section of this manual.
7. Return the seat ring, cage, plug/retainer assembly, and stem to the valve body and completely reassemble the valve package following the appropriate instructions in the Trim Replacement section of this manual.

CAUTION

To avoid excessive leakage and seat erosion, the valve plug must be initially seated with sufficient force to overcome the resistance of the C-seal plug seal and contact the seat ring. You can correctly seat the valve plug by applying the full actuator load. This force will adequately drive the valve plug to the seat ring, thus giving the C-seal plug seal a predetermined permanent set. Once this is done, the plug/retainer assembly, the cage, and the seat ring become a matched set.

With full actuator force applied and the valve plug fully seated, align the actuator travel indicator scale with the lower end of valve travel. Refer to the appropriate actuator instruction manual for information on this procedure.

ENVIRO-SEAL Bellows Seal Bonnet

Replacing a Plain or Extension Bonnet with an ENVIRO-SEAL Bellows Seal Bonnet (Stem/Bellows Assembly)

1. Remove the actuator and bonnet according to steps 1 through 5 of the Replacing Packing procedure in the Maintenance section.
2. Lift out the cage.
3. Remove and discard the existing bonnet gasket. Cover the valve body opening to protect sealing surfaces and to prevent foreign material from entering the valve body cavity.

Note

The ENVIRO-SEAL stem/bellows assembly for easy-e valves is available only with a threaded and drilled plug/adaptor/stem connection. The existing valve plug can be reused with the new stem/bellows assembly or a new plug can be installed.

4. Inspect the existing valve plug. If the plug is in good condition, it can be reused with the new ENVIRO-SEAL stem/bellows assembly. To remove the existing valve plug from the stem, first, place the existing plug stem assembly in a soft-jaw chuck or other type of vise so that the jaws grip a portion of the valve plug that is not a seating surface. Drive out or drill out the pin (key 8).
5. Then, reverse the plug stem assembly in the soft-jaw chuck or vise. Grip the valve stem in an appropriate place and unscrew the existing plug from the valve stem.

CAUTION

When installing a valve plug on the ENVIRO-SEAL stem/bellows assembly, the valve stem must not be rotated. Damage to the bellows may result.

Do not grip the bellows shroud or other parts of the stem/bellows assembly. Grip only the flat areas on the stem where it extends out of the top of the bellows shroud.

Note

The ENVIRO-SEAL stem/bellows assembly has a one-piece stem.

6. To attach the valve plug to the stem of the new ENVIRO-SEAL stem/bellows assembly, it is necessary to first attach the plug to the adaptor (key 24). Locate the adaptor. Notice that a hole has not been drilled in the threads where the plug screws onto the adaptor. Secure the valve plug in a soft-jaw chuck or other type of vise. Do not grip the plug on any seating surface. Position the plug in the chuck or vise for easy threading of the adaptor. Thread the adaptor into the valve plug and tighten to the appropriate torque value.
7. Select the proper size of drill bit and drill through the adaptor using the hole in the valve plug as a guide. Remove any metal chips or burrs and drive in a new pin (key 8, figures 19, 20, and 21) to lock the plug/adaptor assembly together.
8. Attach the plug/adaptor assembly to the ENVIRO-SEAL stem/bellows assembly by first securing the stem/bellows assembly in a soft-jaw chuck or other type of vise so that the jaws of the chuck or vise grip the flats of the stem extending out of the top of the bellows shroud. Screw the valve plug/adaptor assembly onto the valve stem. Tighten the plug/adaptor assembly until it is snug. Then turn the plug/adaptor assembly to the next pin hole in the valve stem. Drive in new pin (key 36, figure 18) to lock the assembly.
9. Inspect the seat ring (key 9). Replace, if necessary.

Table 6. Recommended Torque for ENVIRO-SEAL Bellows Seal Bonnet Packing Flange Nuts

VALVE SIZE, NPS	VALVE STEM DIAMETER THROUGH PACKING	MINIMUM TORQUE		MAXIMUM TORQUE	
		N•m	Lbf•in	N•m	Lbf•in
1/2 - 2	1/2	2	22	4	33
3 - 8	1	5	44	8	67

10. Place a new gasket (key 10) into the valve body in place of the bonnet gasket. Install the new stem/bellows assembly with valve plug/adaptor by placing it into the valve body on top of the new bellows gasket.
11. Place a new gasket (key 22) over the stem/bellows assembly. Place the new ENVIRO-SEAL bonnet over the stem/bellows assembly.

Note

Stud(s) and nut(s) should be installed such that the manufacturer's trademark and material grade marking is visible, allowing easy comparison to the materials selected and documented in the Emerson/Fisher serial card provided with this product.

⚠ WARNING

Personal injury or damage to equipment could occur if improper stud and nut materials or parts are used. Do not operate or assemble this product with stud(s) and nut(s) that are not approved by Emerson/Fisher engineering and/or listed on the serial card provided with this product. Use of unapproved materials and parts could lead to stresses exceeding the design or code limits intended for this particular service. Install studs with the material grade and manufacturer's identification mark visible. Contact your [Emerson sales office](#) or Local Business Partner immediately if a discrepancy between actual parts and approved parts is suspected.

12. Properly lubricate the bonnet stud bolts. Install and tighten the bonnet hex nuts to the proper torque.
13. Install the new packing and the metal packing box parts according to the appropriate arrangement in figure 12 or 13.

Figure 12. PTFE Packing Arrangement for Use in ENVIRO-SEAL Bellows Seal Bonnets

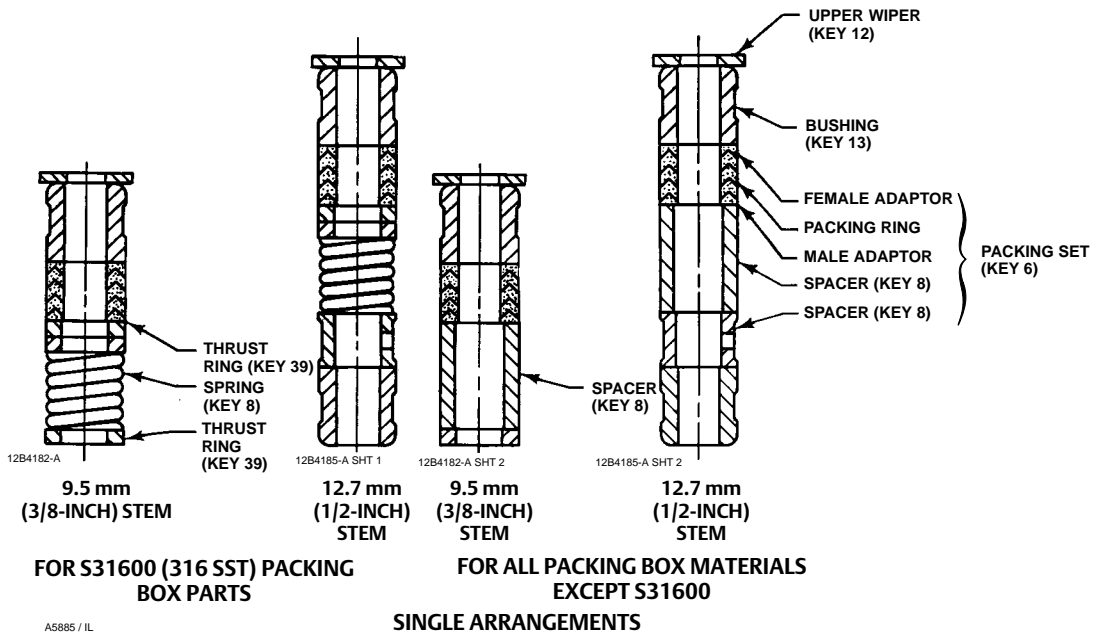

A5885 / IL

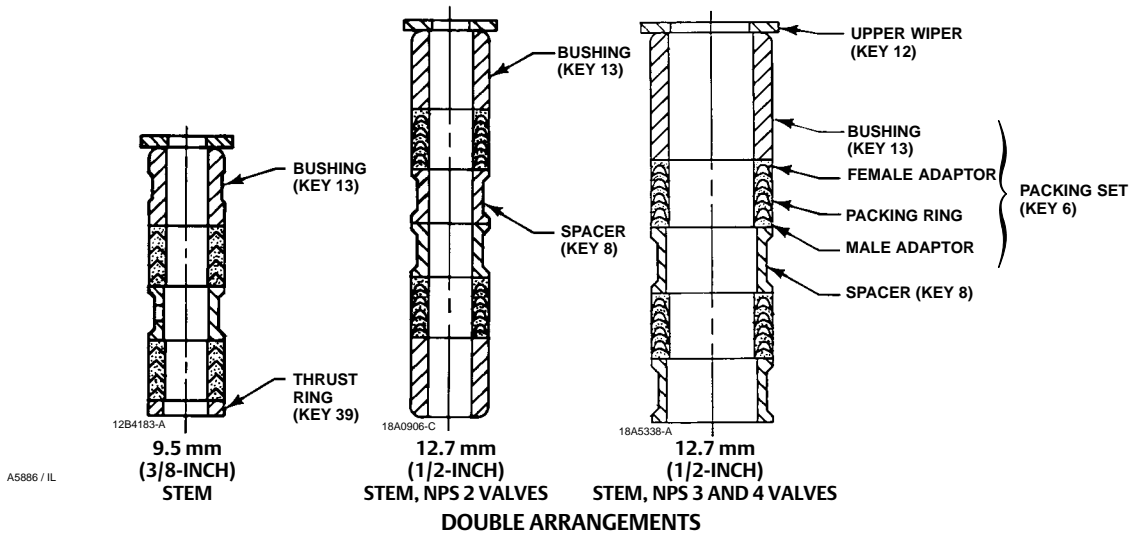

A5886 / IL

14. Install the packing flange. Properly lubricate the packing flange stud bolts and the faces of the packing flange nuts.

For **graphite packing**, tighten the packing flange nuts to the maximum recommended torque shown in table 6. Then, loosen the packing flange nuts, and retighten them to the recommended minimum torque shown in table 6.

For **other packing types**, tighten the packing flange nuts alternately in small equal increments until one of the nuts reaches the minimum recommended torque shown in table 6. Then, tighten the remaining flange nut until the packing flange is level and at a 90-degree angle to the valve stem.

15. Install the travel indicator parts and stem locknuts; mount the actuator on the valve body according to the procedure in the appropriate actuator instruction manual.

Replacement of an Installed ENVIRO-SEAL Bellows Seal Bonnet (Stem/Bellows Assembly)

1. Remove the actuator and bonnet according to steps 1 through 5 of the Replacing Packing procedure of the Maintenance section.
2. Lift out the cage. Remove and discard the existing bonnet gasket and bellows gasket. Cover the valve body opening to protect sealing surfaces and to prevent foreign material from entering the valve body cavity.

Note

The ENVIRO-SEAL stem/bellows assembly for easy-e valves is available only with a threaded and pinned plug/adaptor/stem connection. The existing valve plug can be reused with the new stem/bellows assembly or a new plug can be installed. If the existing valve plug is reused, and the adaptor is in good condition, it may be reused also. However, never reuse an old adaptor with a new valve plug. Using an old adaptor with a new valve plug requires drilling a new pin hole in the adaptor. This drilling weakens the adaptor and may cause failure in service. However, a used valve plug may be reused with a new adaptor.

Figure 13. Double Graphite Ribbon/Filament Arrangements for Use in ENVIRO-SEAL Bellows Seal Bonnets

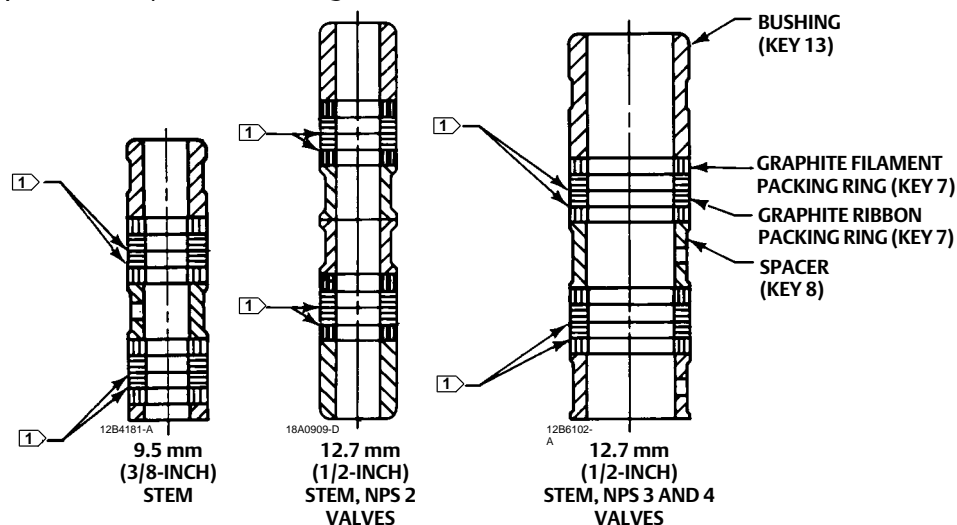

A5887

NOTES:
 1 0.102 mm (0.004 INCH) THICK SACRIFICIAL ZINC WASHERS;
 USE ONLY ONE BELOW EACH GRAPHITE RIBBON RING.

3. Inspect the existing valve plug and adaptor. If they are in good condition, they can be reused with the new stem/bellows assembly and they do not need to be separated.

CAUTION

When removing/installing a valve plug on the ENVIRO-SEAL stem/bellows assembly, the valve stem must not be rotated. Damage to the bellows may result.

Do not grip the bellows shroud or other parts of the stem/bellows assembly. Grip only the flat areas on the stem where it extends out of the top of the bellows shroud.

Note

The ENVIRO-SEAL stem/bellows assembly has a one-piece stem.

4. If the valve plug and adaptor are not in good condition and must be replaced, the valve plug/adaptor assembly must first be removed from the stem/bellows assembly and then the valve plug removed from the adaptor. First, place the stem/bellows assembly and valve plug in a soft-jaw chuck or other type of vise so that the jaws grip a portion of the valve plug that is not a seating surface. Drive out or drill out the pin (key 8, figure 19, 20, or 21). Drive out the pin (key 36, figure 18).
5. Then, reverse the stem/bellows and plug/adaptor assembly in the soft-jaw chuck or vise. Grip the flat areas on the valve stem just below the threads for the actuator/stem connection. Unscrew the plug/adaptor assembly from the stem/bellows assembly. Unscrew the valve plug from the adaptor.
6. To attach either the existing or a new valve plug to the stem of the new ENVIRO-SEAL stem/bellows assembly, first attach the plug to the adaptor (if the valve plug was removed from the adaptor) as follows:
 - Locate the adaptor. Notice that a hole has not been drilled in the new adaptor threads where the plug screws onto the adaptor.
 - Secure the valve plug in a soft-jaw chuck or other type of vise. Do not grip the plug on any seating surface. Position the plug in the chuck or vise for easy threading of the adaptor.
 - Thread the adaptor into the valve plug and tighten to the appropriate torque value.
7. Complete the installation by following steps 7 through 15 of the ENVIRO-SEAL Bellows Seal Bonnet installation instructions given above.

Purging the ENVIRO-SEAL Bellows Seal Bonnet

The ENVIRO-SEAL bellows seal bonnet has been designed so that it can be purged or leak tested. Refer to figure 18 for an illustration of an ENVIRO-SEAL bellows seal bonnet. Perform the following steps for purging or leak testing.

1. Remove the two diametrically opposed pipe plugs (key 16).
2. Connect a purging fluid to one of the pipe plug connections.
3. Install appropriate piping or tubing in the other pipe plug connection to pipe away the purging fluid or to make a connection to an analyzer for leak testing.
4. When purging or leak testing has been completed, remove the piping or tubing and reinstall the pipe plugs (key 16).

Parts Ordering

Each valve body-bonnet assembly is assigned a serial number which can be found on the valve. This same number also appears on the actuator nameplate when the valve is shipped from the factory as part of a control valve assembly. Refer to the serial number when contacting your [Emerson sales office](#) or Local Business Partner for technical assistance. When ordering replacement parts, refer to the serial number and to the eleven-character part number for each part required from the following Parts Kit or Parts List information.

⚠ WARNING

Use only genuine Fisher replacement parts. Components that are not supplied by Emerson Automation Solutions should not, under any circumstances, be used in any Fisher valve, because they may void your warranty, might adversely affect the performance of the valve, and could cause personal injury and property damage.

Parts Kits

Note

Kits do not apply to N10276, N08020, or N04400 trims.

Gasket Kits

Gasket Kits (includes keys 10, 12, 13, and 51; plus 11, 14, and 20 on some restricted capacity valves)

DESCRIPTION	Standard Trim Cage Whisper Trim I Cage Cavitrol III - 1 Stage Cage	Cavitrol III - 2 Stage Cage Whisper Trim III Cage WhisperFlo Cage
	-198 to 593°C (-325 to 1100°F)	
Full Capacity Valves	Part Number	Part Number
NPS 1 & 1-1/4 (NPS 1 EAD)	RGASKETX162	RGASKETX422
NPS 1-1/2 (NPS 2 EAD)	RGASKETX172	RGASKETX432
NPS 2	RGASKETX182	RGASKETX442
NPS 2-1/2 (NPS 3 EAD)	RGASKETX192	RGASKETX452
NPS 3 (NPS 4 EAD)	RGASKETX202	RGASKETX462
NPS 4 (NPS 6 EAD)	RGASKETX212	RGASKETX472
NPS 6	RGASKETX222	RGASKETX482
NPS 8	RGASKETX232	10A3265X152
Restricted Capacity Valves		
NPS 1-1/2 x 1 (NPS 2 x 1 EAD)	RGASKETX242	---
NPS 2 x 1	RGASKETX252	---
NPS 2-1/2 x 1-1/2 (NPS 3 x 1-1/2 EAD)	RGASKETX262	---
NPS 3 x 2 (NPS 4 x 2 EAD)	RGASKETX272	---
NPS 4 x 2-1/2 (NPS 6 x 2-1/2 EAD)	RGASKETX282	---

Packing Kits

Standard Packing Repair Kits (Non Live-Loaded)

Stem Diameter, mm (Inches) Yoke Boss Diameter, mm (Inches)	9.5 (3/8) 54 (2-1/8)	12.7 (1/2) 71 (2-13/16)	19.1 (3/4) 90 (3-9/16)	25.4 (1) 127 (5)	31.8 (1-1/4) 127 (5, 5H)
PTFE (Contains keys 6, 8, 10, 11, and 12)	RPACKX00012	RPACKX00022	RPACKX00032	RPACKX00342	RPACKX00352
Double PTFE (Contains keys 6, 8, 11, and 12)	RPACKX00042	RPACKX00052	RPACKX00062	RPACKX00362	RPACKX00372
PTFE/Composition (Contains keys 7, 8, 11, and 12)	RPACKX00072	RPACKX00082	RPACKX00092	---	---
Single Graphite Ribbon/Filament (Contains keys 7 [ribbon ring], 7 [filament ring], 8, and 11)	RPACKX00102	RPACKX00112	RPACKX00122	---	---
Single Graphite Ribbon/Filament (Contains keys 7 [ribbon ring], 7 [filament ring], and 11)	---	---	---	RPACKX00532	RPACKX00542
Single Graphite Ribbon/Filament (Contains keys 7 [ribbon ring], 7 [filament ring])	RPACKX00132	RPACKX00142	RPACKX00152	---	---
Double Graphite Ribbon/Filament (Contains keys 7 [ribbon ring], 7 [filament ring], 8, and 11)	RPACKX00162	RPACKX00172	RPACKX00182	---	---

Figure 14. Typical HIGH-SEAL Graphite ULF Packing System

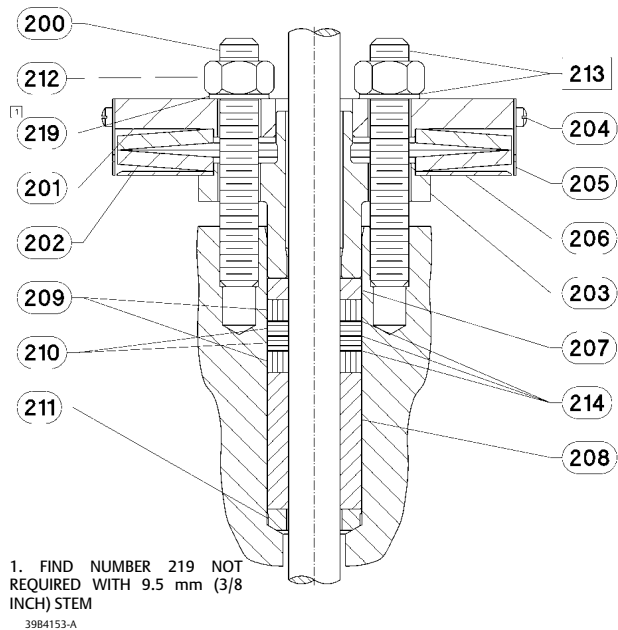

Figure 16. Typical ENVIRO-SEAL Packing System with Graphite ULF Packing

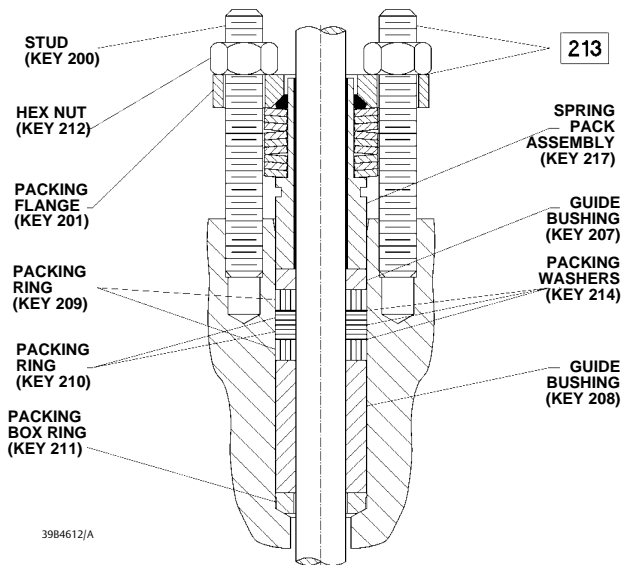

Figure 15. Typical ENVIRO-SEAL Packing System with PTFE Packing

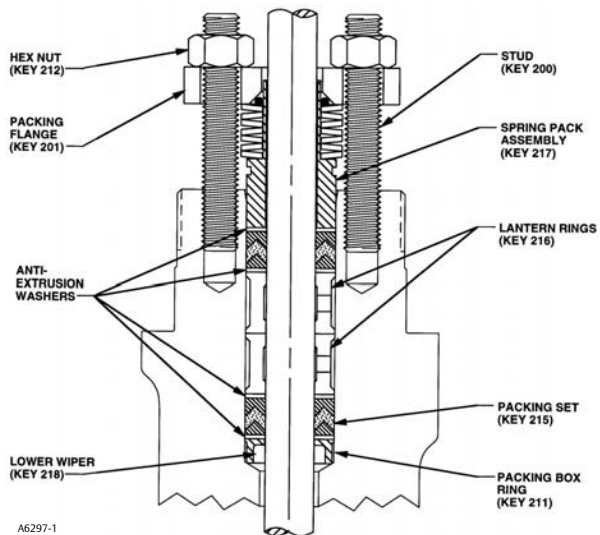
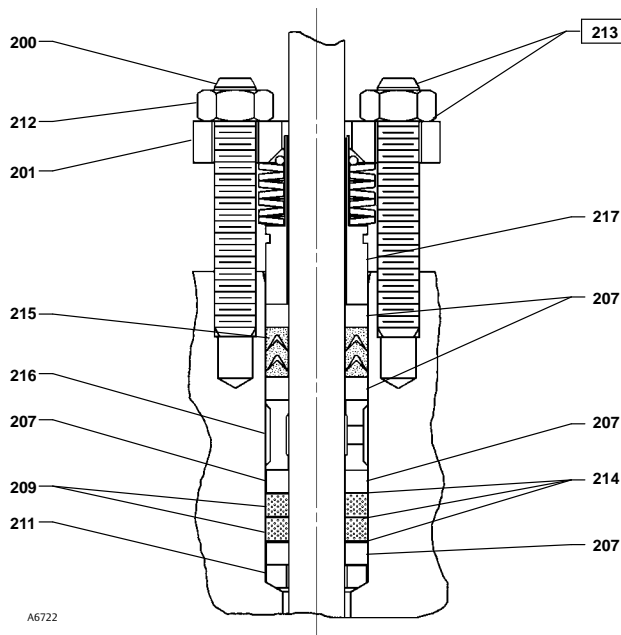

Figure 17. Typical ENVIRO-SEAL Packing System with Duplex Packing



ENVIRO-SEAL Packing Retrofit Kits

Retrofit kits include parts to convert valves with existing standard bonnets to the ENVIRO-SEAL packing box construction. Refer to figure 15 for key numbers for PTFE packing, figure 16 for key numbers for Graphite ULF packing, and figure 17 for key numbers for duplex packing. PTFE kits include keys 200, 201, 211, 212, 214, 215, 217, 218, tag, and cable tie. Graphite ULF kits include keys 200, 201, 207, 208, 209, 210, 211, 212, 214, 216, 217, tag, and cable tie. Duplex kits include keys 200, 201, 207, 209, 211, 212, 214, 215, 216, 217, tag, and cable tie.

Stems and packing box constructions that do not meet Fisher stem finish specifications, dimensional tolerances, and design specifications, may adversely alter the performance of this packing kit.

For part numbers of individual components, refer to instruction manual ENVIRO-SEAL Packing System for Sliding-Stem Valves, [D101642X012](#).

ENVIRO-SEAL Packing Retrofit Kits

PACKING MATERIAL	STEM DIAMETER AND YOKE BOSS DIAMETER, mm (INCH)				
	9.5 (3/8) 54 (2-1/8)	12.7 (1/2) 71 (2-13/16)	19.1 (3/4) 90 (3-9/16)	25.4 (1) 127 (5)	31.8 (1-1/4) 127 (5, 5H)
Double PTFE	RPACKXRT012	RPACKXRT022	RPACKXRT032	RPACKXRT042	RPACKXRT052
Graphite ULF	RPACKXRT262	RPACKXRT272	RPACKXRT282	RPACKXRT292	RPACKXRT302
Duplex	RPACKXRT212	RPACKXRT222	RPACKXRT232	RPACKXRT242	RPACKXRT252

ENVIRO-SEAL Packing Repair Kits

Repair kits include parts to replace the "soft" packing materials in valves that already have ENVIRO-SEAL packing arrangements installed or in valves that have been upgraded with ENVIRO-SEAL retrofit kits. Refer to figure 15 for key numbers for PTFE packing, figure 16 for key numbers for Graphite ULF packing, and figure 17 for key numbers for duplex packing. PTFE repair kits include keys 214, 215, and 218. Graphite ULF repair kits include keys 207, 208, 209, 210, and 214. Duplex repair kits include keys 207, 209, 214, and 215.

Stems and packing box constructions that do not meet Fisher stem finish specifications, dimensional tolerances, and design specifications, may adversely alter the performance of this packing kit.

For part numbers of individual components, refer to instruction manual ENVIRO-SEAL Packing System for Sliding-Stem Valves, [D101642X012](#).

ENVIRO-SEAL Packing Repair Kits

PACKING MATERIAL	STEM DIAMETER AND YOKE BOSS DIAMETER, mm (INCH)				
	9.5 (3/8) 54 (2-1/8)	12.7 (1/2) 71 (2-13/16)	19.1 (3/4) 90 (3-9/16)	25.4 (1) 127 (5)	31.8 (1-1/4) 127 (5, 5H)
Double PTFE (contains keys 214, 215, & 218)	RPACKX00192	RPACKX00202	RPACKX00212	RPACKX00222	RPACKX00232
Graphite ULF (contains keys 207, 208, 209, 210, and 214)	RPACKX00592	RPACKX00602	RPACKX00612	RPACKX00622	RPACKX00632
Duplex (contains keys 207, 209, 214, and 215)	RPACKX00292	RPACKX00302	RPACKX00312	RPACKX00322	RPACKX00332

Parts List

Note

Part numbers are shown for recommended spares only. For part numbers not shown, contact your [Emerson sales office](#) or Local Business Partner.

Bonnet (figure 18)

Key	Description	Part Number
1	Bonnet If you need a bonnet and/or an ENVIRO-SEAL bellows seal bonnet as a replacement part, order by valve size and stem diameter, serial number, and desired material.	
2	Extension Bonnet Baffle	
3	Packing Flange	
3	ENVIRO-SEAL bellows seal packing flange	
4	Packing Flange Stud	
4	ENVIRO-SEAL bellows seal stud bolt	
5	Packing Flange Nut	
5	ENVIRO-SEAL bellows seal packing flange nut	
6*	Packing set, PTFE	See following table
6*	ENVIRO-SEAL bellows seal packing set PTFE (1 req'd for single, 2 req'd for double)	
	9.5 mm (3/8-inch) stem	12A9016X012
	NPS 2 w/ 12.7 mm (1/2-inch) stem	12A9016X012
	NPS 3 & 4 w/ 12.7 mm (1/2-inch) stem (For double PTFE only)(2 req'd)	12A8832X012
7*	Packing Ring, PTFE	See following table
7*	ENVIRO-SEAL bellows seal packing ring Double packing graphite filament (4 req'd)	
	9.5 mm (3/8-inch) stem	1P3905X0172
	NPS 2 w/ 12.7 mm (1/2-inch) stem	1P3905X0172
	NPS 3 & 4 w/ 12.7 mm (1/2-inch) stem	14A0915X042
7*	ENVIRO-SEAL bellows seal packing ring Double packing graphite ribbon (4 req'd)	
	9.5 mm (3/8-inch) stem	18A0908X012
	NPS 2 w/ 12.7 mm (1/2-inch) stem	18A0908X012
	NPS 3 & 4 w/ 12.7 mm (1/2-inch) stem	18A0918X012
8	Spring	
8	Lantern Ring	
8	ENVIRO-SEAL bellows seal spring	
8	ENVIRO-SEAL bellows seal spacer	
10	Special Washer	
11*	Packing Box Ring 9.5 mm (3/8-inch) stem, 316 stainless steel	1J873135072
	12.7 mm (1/2-inch) stem, 316 stainless steel	1J873235072
	19.1 mm (3/4-inch) stem, 316 stainless steel	1J873335072
	25.4 mm (1-inch) stem, 316 stainless steel	1J873435072
	31.8 mm (1-1/4 inch) stem,	

Key	Description	Part Number
	316 stainless steel	1J873535072
12*	Upper Wiper, felt 9.5 mm (3/8-inch) stem	1J872606332
	12.7 mm (1/2-inch) stem	1J872706332
	19.1 mm (3/4-inch) stem	1J872806332
	25.4 mm (1-inch) stem	1J872906332
	31.8 mm (1-1/4 inch) stem	1J873006332
12*	ENVIRO-SEAL bellows seal upper wiper, felt 9.5 mm (3/8-inch) stem	18A0868X012
	NPS 2 w/ 12.7 mm (1/2-inch) stem	18A0868X012
	NPS 3 & 4 w/ 12.7 mm (1/2-inch) stem	18A0870X012
13	Packing Follower	
13*	ENVIRO-SEAL bellows seal bushing For 9.5 mm (3/8-inch) stem (1 req'd), NPS 2 w/ 12.7 mm (1/2-inch) stem (2 req'd)	
	S31600 (316 SST)	18A0820X012
	R30006	18A0819X012
	S31600 chrome coated	11B1155X012
	For NPS 3 & 4 w/ 12.7 mm (1/2-inch) stem (1 req'd)	
	S31600 (316 SST)	18A0824X012
	R30006	18A0823X012
	S31600 chrome coated	11B1157X012
13*	ENVIRO-SEAL bellows seal bushing/liner For 9.5 mm (3/8-inch) stem (1 req'd), NPS 2 w/ 12.7 mm (1/2-inch) stem (2 req'd)	
	N10276 bushing, PTFE/glass liner	12B2713X012
	N10276 bushing, PTFE/carbon liner	12B2713X042
	For NPS 3 & 4 w/ 12.7 mm (1/2-inch) stem (1 req'd)	
	N10276 bushing, PTFE/glass liner	12B2715X012
	N10276 bushing, PTFE/carbon liner	12B2715X042
14	Pipe Plug, for 1/4 NPT tapping in packing box	
14	Lubricator	
14	Lubricator/Isolating Valve	
15	Yoke Locknut	
15	ENVIRO-SEAL bellows seal yoke locknut	
16	Pipe Plug for 1/2 NPT tapped extension bonnets	
16	ENVIRO-SEAL bellows seal pipe plug	
20*	ENVIRO-SEAL bellows seal stem/bellows assembly 1 ply bellows S31600 (316 SST) trim, N06625 bellows NPS 1 or 1-1/4 valve w/ 9.5 mm (3/8-inch) stem	32B4224X012
	NPS 1-1/2 valve w/ 9.5 mm (3/8-inch) stem	32B4225X012
	NPS 2 w/ 12.7 mm (1/2-inch) stem	32B4226X012
	NPS 3 w/ 12.7 mm (1/2-inch) stem	32B4227X012
	NPS 4 w/ 12.7 mm (1/2-inch) stem	32B4228X012
	N06022 trim, N06022 bellows	
	NPS 1 or 1-1/4 valve w/ 9.5 mm (3/8-inch) stem	32B4224X022
	NPS 1-1/2 valve w/ 9.5 mm (3/8-inch) stem	32B4225X022
	NPS 2 w/ 12.7 mm (1/2-inch) stem	32B4226X022
	NPS 3 w/ 12.7 mm (1/2-inch) stem	32B4227X022
	NPS 4 w/ 12.7 mm (1/2-inch) stem	32B4228X022
	2 ply bellows S31600 (316 SST) trim, N06625 bellows NPS 1 or 1-1/4 valve w/ 9.5 mm	

Key	Description	Part Number	Key	Description	Part Number
	(3/8-inch) stem	32B4224X032		19.1 mm (3/4-inch) stem	1V326035072
	NPS 1-1/2 valve w/ 9.5 mm (3/8-inch) stem	32B4225X032		25.4 mm (1-inch) or 31.8 mm (1-1/4 inch) stem	1V334035072
	NPS 2 w/ 12.7 mm (1/2-inch) stem	32B4226X032	9*	Seat Ring	See following table
	NPS 3 w/ 12.7 mm (1/2-inch) stem	32B4227X032	9*	EAD liner	See following table
	NPS 4 w/ 12.7 mm (1/2-inch) stem	32B4228X032	10*	Bonnet Gasket	See following table
	N06022 trim, N06022 bellows		11*	Cage Gasket	See following table
	NPS 1 or 1-1/4 valve w/ 9.5 mm (3/8-inch) stem	32B4224X042	12*	Spiral Wound Gasket	See following table
	NPS 1-1/2 valve w/ 9.5 mm (3/8-inch) stem	32B4225X042	13*	Seat Ring Gasket	See following table
	NPS 2 w/ 12.7 mm (1/2-inch) stem	32B4226X042	14*	Adaptor Gasket	See following table
	NPS 3 w/ 12.7 mm (1/2-inch) stem	32B4227X042	15	Cap Screw	
	NPS 4 w/ 12.7 mm (1/2-inch) stem	32B4228X042	15	Stud Bolt	
22*	ENVIRO-SEAL bellows seal bonnet gasket, graphite/laminate		16	Hex Nut	
	NPS 1 or 1-1/4 valve	12B6316X022	17	Pipe Plug, for use in valves with drain tapping only	
	NPS 1-1/2 valve	12B6317X022	18	Flow Direction Arrow	
	NPS 2 valve	12B6318X022	19	Drive Screw	
	NPS 3 valve	12B6319X022	20*	Adaptor Gasket	See following table
	NPS 4 valve	12B6320X022	26	Load Ring	
24	ENVIRO-SEAL bellows seal adaptor		27*	Shim	See following table
25	Cap Screw		31*	Whisper Trim III Cage Retainer for Levels A3, B3 & C3 (NPS 6 ED only)	
26	Hex Nut			410 stainless steel	22A3255X012
27	Pipe Nipple for lubricator/isolating valve			WCC steel (ENC)	22A3256X012
28	Warning Nameplate for ENVIRO-SEAL bellows			316 stainless steel (ENC)	22A3256X022
29	Drive Screw for ENVIRO-SEAL bellows			316 stainless steel w/CoCr-A bore	22A3257X012
34	Lubricant, anti-seize (not furnished with valve)			316 stainless steel (Cr Cr)	31A9792X012
36*	ENVIRO-SEAL bellows seal pin, N06022	12B3951X012	31*	Whisper Trim III Cage Retainer & Baffle Ass'y for Level D3 (NPS 6 ED only)	
37	Warning Tag for ENVIRO-SEAL bellows			410 stainless steel retainer & steel baffle	22A3258X012
38	Tie for ENVIRO-SEAL bellows			WCC steel (ENC) retainer & steel baffle	22A3258X022
39	ENVIRO-SEAL bellows seal thrust ring			316 stainless steel (ENC) retainer & steel baffle	22A3258X052
				316 stainless steel w/CoCr-A retainer & steel baffle	22A3258X032
				316 stainless steel (ENC) retainer & 316 stainless steel baffle	22A3258X042
				316 stainless steel (Cr Cr) retainer & 316 stainless steel baffle	22A3258X062
			32	Whisper Trim III Bonnet Spacer	
			51*	Shim	See following table
			54	Wire	

Valve Body (figures 19-24)

1	Valve Body	
	If you need a valve body as a replacement part, order by valve size, serial number, and desired material.	
2*	Valve Plug	See following tables
3*	Cage	See following tables
4	Cage Adaptor	
5	Seat Ring Adaptor	
6*	Piston Ring(s)	See following table
7*	Valve Plug Stem	See following tables
8*	Pin, 316 stainless steel	
	9.5 mm (3/8-inch) stem	1V322635072
	12.7 mm (1/2-inch) stem	1V322735072

C-seal Trim (figure 6)

2*	Valve Plug/Retainer	see following table
3*	Cage	see following table
6*	Piston Ring, graphite	see following table
7*	Valve Plug Stem, S20910	see following table
9*	Seat Ring	see following table
64*	C-seal, N07718	see following table

Figure 18. Typical Bonnets

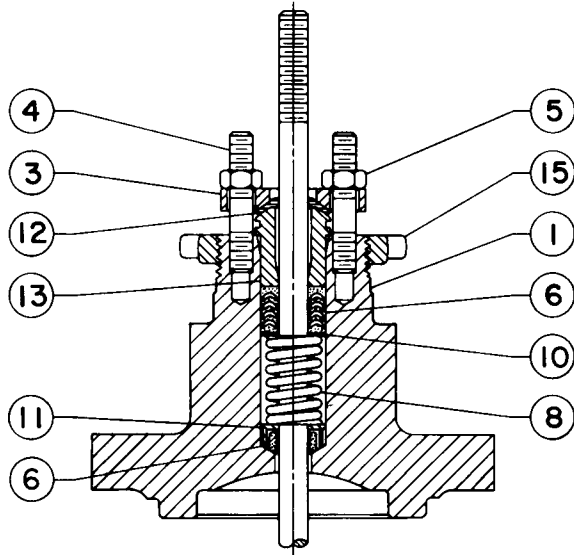

E0201

PLAIN BONNET

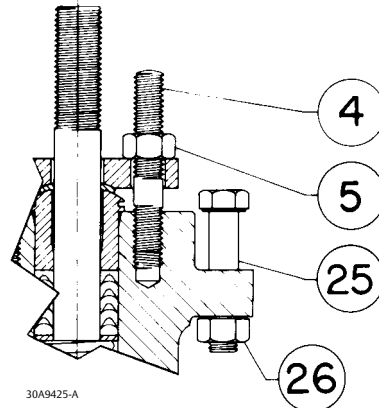

30A9425-A

DETAIL OF 127 mm (5-INCH) YOKE
BOSS ACTUATOR BOLTING

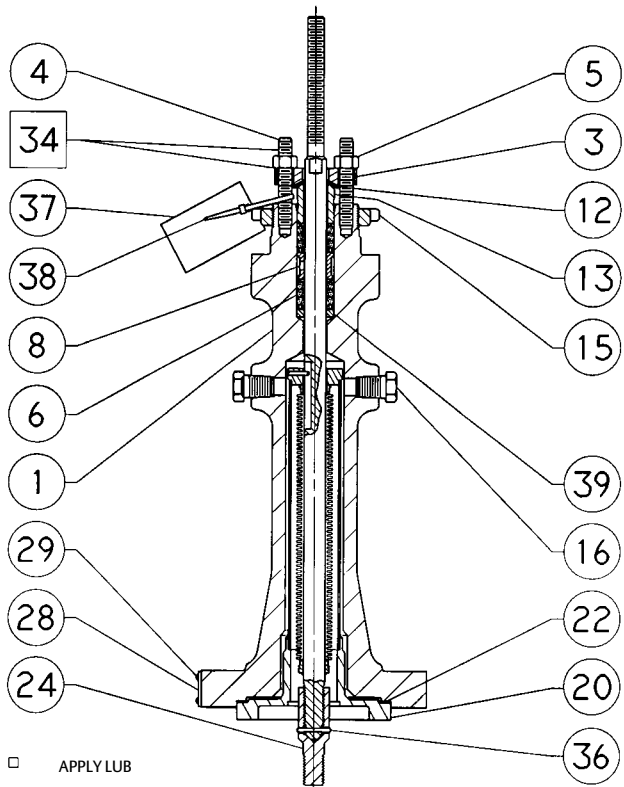

□ APPLY LUB

42B3947-A

ENVIRO-SEAL
BELLOWS SEAL BONNET

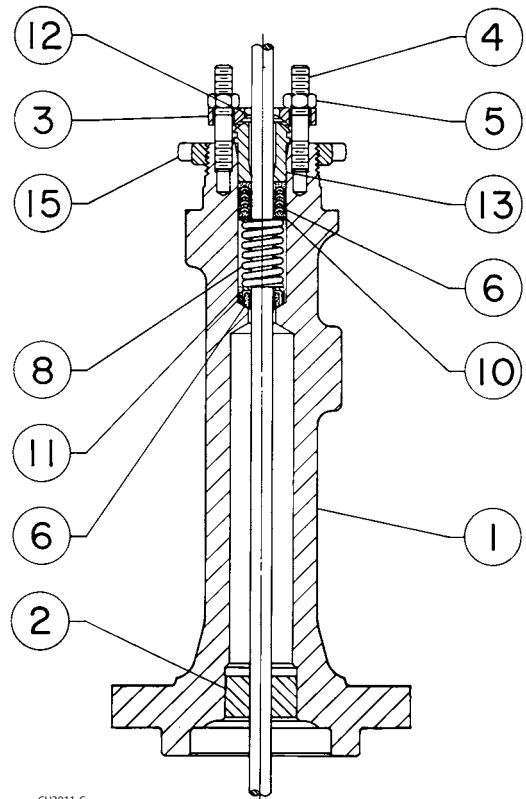

CU3911-C

STYLE 1 OR 2
EXTENSION BONNET

Keys 6*, 7*, 8, and 10 Packing Box Parts

DESCRIPTION		KEY NO.	STEM DIAMETER, mm (INCHES)					
			9.5 (3/8)	12.7 (1/2)	19.1 (3/4)	25.4 (1)	31.8 (1-1/4)	
PTFE V-Ring Packing	Packing Set, PTFE (1 req'd for single, 2 req'd for double) ⁽¹⁾	6	1R290001012	1R290201012	1R290401012	1R290601012	1R290801012	
	Spring, Stainless Steel (for single only)	8	1F125437012	1F125537012	1F125637012	1D582937012	1D387437012	
	Lantern Ring, Stainless Steel (for double only)	8	1F364135072	1J962335072	0N028435072	0U099735072	0W087135072	
	Quantity required	Double	---	1	2	1	1	1
	Special Washer, Stainless Steel (for single only)	10	1F125236042	1F125136042	1F125036042	1H982236042	1H995936042	
PTFE/Composition Packing	Packing Ring, PTFE composition	7	1F3370X0012	1E319001042	1E319101042	1D7518X0012	1D7520X0012	
	Quantity required	Double	---	7	10	8	8	8
	Lantern Ring, Stainless Steel (1 required)	8	1F364135072	1J962335072	0N028435072	0U099735072	0W087135072	
Graphite Ribbon/Filament	Graphite Ribbon Ring	7	1V3160X0022	1V3802X0022	1V2396X0022	1U6768X0022	1V5666X0022	
	Quantity Required	Single	---	2	2	2	2	
		Double	---	3	3	3	3	
	Graphite Filament Ring	7	1F3370X0322	1E3190X0222	1E3191X0282	1D7518X0132	1D7520X0162	
	Quantity Required	Single	---	2	2	3	3	
		Double	---	4	4	5	5	
	Lantern Ring	8	1F364135072	1J962335072	0N028435072	0U099735072	0W087135072	
	Quantity Required	Single	---	2	3	2	2	
Double		---	1	2	1	1		

1. Key 6 for double construction contains one extra packing ring for the 9.5 mm (3/8-inch) stem and one extra lower wiper for all sizes. Discard upon assembly.

Keys 2*, 7*, and 8* Valve Plug and Stem Assembly for Plain Bonnet

VALVE SIZE, NPS		STEM DIAMETER & VSC SIZE		416 STAINLESS STEEL HARDENED (STD)	316 STAINLESS STEEL ⁽¹⁾	316 STAINLESS STEEL w/CoCr-A ON SEAT ⁽¹⁾	316 STAINLESS STEEL w/CoCr-A ON SEAT & GUIDE ⁽¹⁾	316 STAINLESS STEEL w/CoCr-A ON SEAT & GUIDE HIGH TEMPERATURE ⁽²⁾
ED	EAD	mm	Inches					
1 or 1-1/4	1	9.5	3/8	1V6571X0032	1V6571X0052	11A5315X032	11A5317X042	11A5319X022
		12.7	1/2	1V6572X0022	1V6572X0062	11A5316X022	11A5318X042	11A5320X022
1-1/2	2	9.5	3/8	1V6573X0042	1V6573X0052	11A5321X022	10A4438X022	11A5322X022
		12.7	1/2	1V6574X0012	1V6574X0032	---	10A4611X042	11A5323X022
1-1/2 x 1	2 x 1	9.5	3/8	1V6571X0042	1V6571X0092	---	11A5317X072	---
		12.7	1/2	1V6572X0042	---	---	11A5318X032	---
2 or 3 x 2	4 x 2	12.7	1/2	1V6575X0052	1V6575X0062	11A5324X022	11A5326X022	11A5328X022
		19.1	3/4	1V6576X0012	---	---	11A5327X032	---
2 x 1	---	12.7	1/2	1V6572X0022	1V6572X0062	11A5316X022	11A5318X042	11A5320X022
2-1/2 or 4 x 2-1/2	3 or 6 x 2-1/2	12.7	1/2	1V6577X0042	1V6577X0062	11A5330X022	11A5332X022	11A5334X042
		19.1	3/4	1V6578X0012	1V6578X0022	11A5331X022	---	11A5335X022
2-1/2 x 1-1/2	3 x 1-1/2	12.7	1/2	1V6574X0012	1V6574X0032	---	10A4611X042	11A5323X022
3	4	12.7	1/2	1V6579X0092	1V6579X0112	11A5336X032	11A5337X082	11A5339X022
4	6	12.7	1/2	1V6581X0042	1V6581X0052	11A5341X032	11A5344X022	11A5347X022
		19.1	3/4	1V6582X0022	1V6582X0072	---	11A5345X042	11A5348X092
6	---	19.1	3/4	1V6584X0042	1V6584X0062	11A5350X032	21A5351X062	21A5353X042
8	---	19.1	3/4	21A5356X052	21A5356X132	---	21A5362X062	21A5365X052

1. Not for use with 17-4PH stainless steel cages above 210°C (410°F) or CoCr-A cages above 427°C (800°F); use high temperature valve plugs for these applications.
 2. For use with 17-4PH stainless steel cages between 210°C (410°F) and 427°C (800°F) and with CoCr-A cages over 427°C (800°F) (the letter "H" is stamped on top for identification).

Keys 2*, 7*, and 8* Valve Plug and Stem Assembly for Style 1 Extension Bonnet

VALVE SIZE, NPS		STEM DIAMETER & VSC SIZE		416 STAINLESS STEEL HARDENED (STD)	316 STAINLESS STEEL ⁽¹⁾	316 STAINLESS STEEL w/CoCr-A ON SEAT ⁽¹⁾	316 STAINLESS STEEL w/CoCr-A ON SEAT & GUIDE ⁽¹⁾	316 STAINLESS STEEL w/CoCr-A ON SEAT & GUIDE HIGH TEMPERATURE ⁽²⁾
ED	EAD	mm	Inches					
1 or 1-1/4	1	9.5	3/8	1V6571X0072	1V6571X0062	---	11A5317X082	---
		12.7	1/2	1V6572X0032	---	11A5316X032	---	11A5320X032
1-1/2	2	9.5	3/8	1V6573X0072	---	11A5321X042	10A4438X032	11A5322X032
		12.7	1/2	1V6574X0052	---	---	10A4611X112	---
1-1/2 x 1	2 x 1	9.5	3/8	1V6571X0102	---	---	11A5317X052	11A5319X072
		12.7	1/2	1V6572X0152	---	---	---	---
2 or 3 x 2	4 x 2	12.7	1/2	1V6575X0182	1V6575X0122	11A5324X042	11A5326X062	11A5328X032
2 x 1	---	12.7	1/2	1V6572X0032	---	11A5316X032	---	11A5320X032
2-1/2 or 4 x 2-1/2	3 or 6 x 2-1/2	12.7	1/2	1V6577X0052	---	---	11A5332X202	11A5334X062
2-1/2 x 1-1/2	3 x 1-1/2	12.7	1/2	1V6574X0052	---	---	10A4611X112	---
3	4	12.7	1/2	1V6579X0082	1V6579X0072	---	11A5337X062	11A5339X032
4	6	12.7	1/2	1V6581X0072	1V6581X0062	---	11A5344X052	11A5347X032
6	---	19.1	3/4	1V6584X0052	1V6584X0112	---	21A5351X052	21A5353X032
8	---	19.1	3/4	21A5356X082	21A5356X262	---	---	21A5365X022

1. Not for use with 17-4PH stainless steel cages above 210°C (410°F) or CoCr-A cages above 427°C (800°F); use high temperature valve plugs for these applications.
2. For use with 17-4PH stainless steel cages between 210°C (410°F) and 427°C (800°F) and with CoCr-A cages over 427°C (800°F) (the letter "H" is stamped on top for identification).

Key 2* Standard Valve Plug

VALVE SIZE, NPS		STEM DIAMETER & VSC SIZE		416 STAINLESS STEEL HARDENED (STD)	316 STAINLESS STEEL ⁽¹⁾	316 STAINLESS STEEL w/CoCr-A ON SEAT ⁽¹⁾	316 STAINLESS STEEL w/CoCr-A ON SEAT & GUIDE ⁽¹⁾	316 STAINLESS STEEL w/CoCr-A ON SEAT & GUIDE HIGH TEMPERATURE ⁽²⁾
ED	EAD	mm	Inches					
1 or 1-1/4 or 1-1/2 x 1	1 or 2 x 1	9.5	3/8	1V657146172	1V657135072	11A5315X012	11A5317X012	11A5319X012
		12.7	1/2	1V657246172	1V657235072	11A5316X012	11A5318X012	11A5320X012
1-1/2	2	9.5	3/8	1V657346172	1V637335072	11A5321X012	10A4438X012	11A5322X012
		12.7	1/2	1V657446172	1V657435072	10A4439X012	10A4611X012	11A5323X012
2 or 3 x 2	4 x 2	12.7	1/2	1V657546172	1V657535072	11A5324X012	11A5326X012	11A5328X012
		19.1	3/4	1V657646172	1V657635072	11A5325X012	11A5327X012	11A5329X012
2 x 1	---	12.7	1/2	1V657246172	1V657235072	11A5316X012	11A5318X012	11A5320X012
2-1/2 or 4 x 2-1/2	3 or 6 x 2-1/2	12.7	1/2	1V657746172	1V657735072	11A5330X012	11A5332X012	11A5334X012
		19.1	3/4	1V657846172	1V657835072	11A5331X012	11A5333X012	11A5335X012
2-1/2 x 1-1/2	3 x 1-1/2	12.7	1/2	1V657446172	1V657435072	10A4439X012	10A4611X012	11A5323X012
3	4	12.7	1/2	1V657946172	1V657935072	11A5336X012	11A5337X012	11A5339X012
		19.1	3/4	1V658046172	1V658035072	10A5104X012	11A5338X012	11A5340X012
4	6	12.7	1/2	1V658146172	1V658135072	11A5341X012	11A5344X012	11A5347X012
		19.1	3/4	1V658246172	1V658235072	11A5342X012	11A5345X012	11A5348X012
		25.4	1	1V658346172	1V658335072	11A5343X012	11A5346X012	11A5349X012
6	---	19.1	3/4	1V658446172	1V658435072	11A5350X012	21A5351X012	21A5353X012
		25.4	1	1V658546172	1V658535072	10A5107X012	20A0103X012	21A5354X012
		31.8	1-1/4	1V658646172	1V658635072	10A5108X012	20A4608X012	21A5355X012
8	---	19.1	3/4	21A5356X012	21A5356X022	21A5359X012	21A5362X012	21A5365X012
		25.4	1	21A5357X012	21A5357X022	21A5360X012	21A5363X012	21A5366X012
		31.8	1-1/4	21A5358X012	21A5358X022	21A5361X012	21A5364X012	21A5367X012

1. Not for use with 17-4PH stainless steel cages above 210°C (410°F) or CoCr-A cages above 427°C (800°F); use high temperature valve plugs for these applications.
2. For use with 17-4PH stainless steel cages between 210°C (410°F) and 427°C (800°F) and with CoCr-A cages over 427°C (800°F) (the letter "H" is stamped on top for identification).

Key 2* Valve Plug (Multiple Piston Rings) for Class IV Shutoff (Fisher ED Only)

VALVE SIZE, NPS	STEM DIAMETER & VSC SIZE		416 STAINLESS STEEL HARDENED (STD)	316 STAINLESS STEEL W/CoCr-A ON SEAT & GUIDE HIGH TEMPERATURE ⁽²⁾
	mm	Inches		
4	12.7	1/2	27A3932X012	27A3941X012
	19.1	3/4	27A3933X012	27A3942X012
6	19.1	3/4	27A3944X012	27A3953X012
	25.4	1	27A3945X012	27A3954X012
8	19.1	3/4	27A3956X012	27A3965X012
	25.4	1	27A3957X012	27A3966X012

1. Not for use with 17-4PH stainless steel cages above 210°C (410°F) or CoCr-A cages above 427°C (800°F); use high temperature valve plugs for these applications.
 2. For use with 17-4PH stainless steel cages between 210°C (410°F) and 427°C (800°F) and with CoCr-A cages over 427°C (800°F) (the letter "H" is stamped on top for identification).

Key 2* Whisper Trim III Valve Plug (NPS 6 Fisher ED Only)

STEM DIAMETER & VSC SIZE		17-4PH STAINLESS STEEL (H900)	316 STAINLESS STEEL	316 STAINLESS STEEL w/ CoCr-A ON SEAT	316 STAINLESS STEEL w/ CoCr-A ON SEAT & GUIDE	316 STAINLESS STEEL w/ CoCr-A ON SEAT & GUIDE ⁽¹⁾
mm	Inches					
19.1	3/4	22A3259X012	22A3259X022	22A3260X012	22A3261X012	22A3267X012
25.4	1	22A3262X012	22A3262X022	22A3263X012	22A3264X012	22A3268X012

1. High temperature.

Key 3* Quick Opening Cage

VALVE SIZE, NPS		17-4PH STAINLESS STEEL (H900)	316 STAINLESS STEEL		Alloy 6
ED	EAD		Chrome Plated	ENC	
1, 1-1/4, 1-1/2 x 1, or 2 x 1	1 or 2 x 1	2U215033272	2U691146102	2U740348932	2U215039102
	2 or 3 x 1-1/2	2U219233272	2U691846102	2U725448932	2U219239102
1-1/2 or 2-1/2 x 1-1/2	4 x 2	2U223433272	2U692146102	2U740448932	2U223439102
	3 or 6 x 2-1/2	2U227633272	2U692446102	2U740548932	2U227639102
2-1/2 or 4 x 2-1/2	4	2U231833272	2U692746102	2U740648932	2U231839102
	6	2U236033272	2U693046102	2U740748932	2U236039102
3	---	2U506333272	2U693546102	2U806948932	2U506339102
	---	20A3249X012	20A4350X012	20A5469X012	20A3249X092

Key 3* Linear Cage

VALVE SIZE, NPS		17-4PH STAINLESS STEEL (H900)	316 STAINLESS STEEL		Alloy 6
ED	EAD		Chrome Plated	ENC	
1, 1-1/4, 1-1/2 x 1, or 2 x 1	1 or 2 x 1	2U215633272	2U691746102	2U741448932	2U215639102
	2 or 3 x 1-1/2	2U219833272	2U692046102	2U741548932	2U219839102
1-1/2 or 2-1/2 x 1-1/2	4 x 2	2U224033272	2U692346102	2U741648932	2U224039102
	3 or 6 x 2-1/2	2U228233272	2U692646102	2U741748932	2U228239102
2-1/2 or 4 x 2-1/2	4	2U232433272	2U692946102	2U741848932	2U232439102
	6	2U236633272	2U693346102	2U741948932	2U236639102
3	---	2U506133272	2U693846102	2U806848932	2U506139102
	---	20A3247X012	20A4349X012	20A5468X012	20A3247X092

Key 3* Equal Percentage Cage

VALVE SIZE, NPS		17-4PH STAINLESS STEEL (H900)	316 STAINLESS STEEL		Alloy 6
ED	EAD		Chrome Plated	ENC	
1, 1-1/4, 1-1/2 x 1, or 2 x 1	1 or 2 x 1	2U215333272	2U691346102	2U740848932	2U215339102
	2 or 3 x 1-1/2	2U219533272	2U691946102	2U740948932	2U219539102
1-1/2 or 2-1/2 x 1-1/2	4 x 2	2U223733272	2U692246102	2U741048932	2U223739102
	3 or 6 x 2-1/2	2U227933272	2U692546102	2U741148932	2U227939102
2-1/2 or 4 x 2-1/2	4	2U232133272	2U692846102	2U741248932	2U232139102
	6	2U236333272	2U693146102	2U741348932	2U236339102
3	---	2U505933272	2U693746102	2U806748932	2U505939102
	---	20A3245X012	20A4348X012	20A5467X012	20A3245X092

Key 3* Whisper Trim III Cage (NPS 6 Fisher ED only)

LEVEL	416 STAINLESS STEEL	316 STAINLESS STEEL (ENC)	316 STAINLESS STEEL (Cr Cr)
A3	32A3248X012	32A3251X012	32A3336X012
B3	32A3249X012	32A3252X012	32A3337X012
C3	32A3250X012	32A3253X012	32A3338X012
D3	32A6217X012	32A6220X012	32A6741X012

Key 3* Whisper Trim I Cage, 17-4PH stainless steel (H900)

VALVE SIZE, NPS		PART NUMBER
ED	EAD	
1, 1-1/4, 1-1/2 x 1, or 2 x 1 1-1/2 or 2-1/2 x 1-1/2 2 or 3 x 2 2-1/2 or 4 x 2-1/2	1 or 2 x 1 2 or 3 x 1-1/2 4 x 2 3 or 6 x 2-1/2	2V502333272 2V502433272 2V502533272 2V502633272 2V502733272 23A8915X032 23A8913X032
3 4 6	4 6 ---	

Key 6* Standard Piston Ring

VALVE SIZE, NPS		TO 427°C (800°F) (OXIDIZING) TO 482°C (900°F) (NON-OXIDIZING) GRAPHITE	482 TO 593°C (901 TO 1100°F) GRAPHITE
ED	EAD		
1, 1-1/4, 1-1/2 x 1, or 2 x 1	1 or 2 x 1	1U2174X0012	1U2174X0022
1-1/2 or 2-1/2 x 1-1/2	2 or 3 x 1-1/2	1U2216X0012	1U2216X0022
2 or 3 x 2 2-1/2 or 4 x 2-1/2 3 4 6 8	4 x 2 3 or 6 x 2-1/2 4 6 --- ---	1U2258X0012 1U2300X0012 1U2342X0012 1U2392X0012 1U5069X0012 10A3262X022	1U2258X0022 1U2300X0022 1U2342X0022 1U2392X0022 1U5069X0022 10A3262X032

Key 6* Multiple Piston Rings for Class IV Shutoff (Fisher ED Only)

VALVE SIZE, NPS	NUMBER REQUIRED	TO 427°C (800°F) (OXIDIZING) TO 482°C (900°F) (NON-OXIDIZING) GRAPHITE	482 TO 593°C (901 TO 1100°F) GRAPHITE
4	3	17A3988X012	17A3988X022
6	3	17A3990X012	17A3990X022
8	2	17A3991X012	17A3991X022

Key 6* Whisper Trim III Piston Ring (NPS 6 Fisher ED only)

GRAPHITE	
TO 427°C (800°F) (OXIDIZING), TO 482°C (900°F) (NON-OXIDIZING)	482 TO 593°C (901 TO 1100°F)
11A9727X022	11A9727X032

Key 7* Fisher ED Valve Plug Stem for Class IV Shutoff (ED only)

VALVE SIZE, NPS	STEM DIAMETER & VSC SIZE		PLAIN BONNET			EXTENSION BONNET		
			Stem Length		Part Number	Style 1		Part Number
			mm	Inches		mm	Inches	
4	12.7	1/2	318	12.5	1U230535162	421	16.5625	1U230635162
	19.1	3/4	394	15.5	1K587735162	502	19.75	1U444635162
6	19.1	3/4	394	15.5	1K587735162	502	19.75	1U444635162
	25.4 ⁽¹⁾	1 ⁽¹⁾	260	10.25	1N704735162	---	---	---

1. Fisher 667 actuator only.

Key 7* Whisper Trim III Valve Stem, 316 Stainless Steel (NPS 6 Fisher ED Only)

STEM DIAMETER & VSC SIZE		PLAIN BONNET			EXTENSION BONNET					
		Stem Length		Part Number	Style 1			Style 2		
		mm	Inches		mm	Inches	Part Number	mm	Inches	Part Number
19.1	3/4	443	17.4375	1U294135162	533	21	1U928235162	616	24.25	1U6276X0012
25.4	1	505	19.875	1P847635162	---	---	---	---	---	---

Key 7* Fisher ED Valve Plug Stem, 316 Stainless Steel (not for Whisper Trim III cage)

VALVE SIZE, NPS	STEM DIAMETER & VSC SIZE	PLAIN BONNET ⁽³⁾					EXTENSION BONNET					
		Stem Length				Part Number	Style 1 ⁽⁴⁾			Style 2		
		mm		Inches			Stem Length		Part Number	Stem Length		Part Number
		mm	Inches	mm	Inches		mm	Inches		mm	Inches	
Full Capacity	1, 1-1/4, or 1-1/2	9.5	3/8	225	8.875	1U388835162	311	12.25	1U217735162	405	15.9375	10A8823X022
		12.7	1/2	300	11.8125	1U389035162	402	15.8125	1U217935162	473	18.625	1U218035162
	2	12.7	1/2	311	12.25	1K586935162	413	16.25	1U226335162	614	24.1875	1U226435162
		19.1	3/4	372	14.625	1U226535162	483	19	1L400135162	---	---	---
	2-1/2	12.7	1/2	321	12.625	1U230535162	421	16.5625	1U230635162	624	24.5625	1U230735162
		19.1	3/4	381	15	1U230835162	502	19.75	1U444635162	---	---	---
	3	12.7	1/2	321	12.625	1U230535162	421	16.5625	1U230635162	624	24.5625	1U230735162
		19.1	3/4	381	15	1U230835162	502	19.75	1K588035162	---	---	---
	4	12.7	1/2	321	12.625	1U230535162	421	16.5625	1U230635162	624	24.5625	1U230735162
		19.1	3/4	394	15.5	1K587735162	502	19.75	1U444635162	694	27.3125	1U240035162
		25.4 ⁽¹⁾	1 ⁽¹⁾	464	18.25	1K759035162	---	---	---	---	---	---
		25.4 ⁽²⁾	1 ⁽²⁾	489	19.25	1U217535162	---	---	---	---	---	---
6	19.1	3/4	403	15.875	1L996435162	511	20.125	1U507135162	699	27.5	1U524435162	
	25.4	1	499	19.625	1N704735162	630	24.8125	1K785135162	---	---	---	
8	31.8	1-1/4	508	20	1K415435162	656	25.8125	1R562435162	---	---	---	
	19.1	3/4	492	19.375	1K588035162	533	21	1U928235162	---	---	---	
8	25.4	1	614	24.1875	1K7891X0012	614	24.1875	1K7891X0012	---	---	---	
	31.8	1-1/4	705	27.4375	1L2298X0012	705	29.4375	1L2298X0012	---	---	---	
Restricted Capacity	1-1/2 x 1	9.5	3/8	241	9.375	1U223635162	324	12.75	1U227035162	418	16.4375	1U227235162
		12.7	1/2	311	12.25	1K586935162	413	16.25	1U226335162	---	---	---
	2 x 1 or 2-1/2 x 1-1/2	12.7	1/2	300	11.8125	1U389035162	402	15.8125	1U217935162	605	23.8125	1U389335162
		12.7	1/2	311	12.25	1K586935162	413	16.25	1U226335162	614	24.1875	1U226435162
3 x 2	19.1	3/4	372	14.625	1U226535162	483	19	1L400135162	---	---	---	
	12.7	1/2	321	12.625	1U230535162	421	16.5625	1U230635162	624	24.5625	1U230735162	
4 x 2-1/2	19.1	3/4	381	15	1U230835162	502	19.75	1U444635162	681	26.8125	1U232335162	

1. Fisher 667 actuator.
 2. Fisher 657 or 585C size 60-130 actuator.
 3. Plain bonnet is standard for NPS 8 cast iron and WCC valve bodies.
 4. Style 1 is standard for NPS 8 316 SST valve bodies.

Key 7* Fisher EAD Valve Plug Stem for Plain and Extension Bonnets

VALVE SIZE, NPS	STEM DIAMETER & VSC SIZE	PLAIN BONNET					EXTENSION BONNET					
		Stem Length				Part Number	Style 1			Style 2		
		mm		Inches			Stem Length		Part Number	Stem Length		Part Number
		mm	Inches	mm	Inches		mm	Inches		mm	Inches	
Full Capacity	1 or 2	9.5	3/8	225	8.875	1U388835162	311	12.25	1U217735162	405	16	1U217835162
		12.7	1/2	300	11.8125	1U389035162	402	15.8125	1U217935162	---	---	---
	3 or 4	12.7	1/2	321	12.625	1U230535162	421	16.5625	1U230635162	624	24.5625	1U230735162 ⁽³⁾
		19.1	3/4	381	15	1U230835162	502	19.75	1U444635162	---	---	---
	6	12.7	1/2	321	12.625	1U230535162	421	16.5625	1U230635162	---	---	---
		19.1	3/4	394	15.5	1K587735162	502	19.75	1U444635162	694	27.3125	1U240035162
25.4 ⁽¹⁾	1 ⁽¹⁾	464	18.25	1K759035162	---	---	---	---	---	---		
25.4 ⁽²⁾	1 ⁽²⁾	489	19.25	1U217535162	---	---	---	---	---	---		
Restricted Capacity	2 x 1	9.5	3/8	241	9.375	1U223635162	324	12.75	1U227035162	---	---	---
		12.7	1/2	311	12.25	1K586935162	413	16.25	1U226335162	---	---	---
	3 x 1-1/2	12.7	1/2	300	11.8125	1U389035162	402	15.8125	1U217935162	---	---	---
		12.7	1/2	311	12.25	1K586935162	413	16.25	1U226335162	---	---	---
4 x 2	19.1	3/4	372	14.5	1U226535162	483	19	1L400135162	---	---	---	
	12.7	1/2	321	12.625	1U230535162	421	16.5625	1U230635162	---	---	---	
6 x 2-1/2	19.1	3/4	381	15	1U230835162	502	19.75	1U444635162	---	---	---	

1. Fisher 667 actuator.
 2. Fisher 657 or 585C size 60-130 actuator.
 3. For NPS 4 valve size only.

Key 9* Seat Ring (not for Whisper Trim III cage)

VALVE SIZE, NPS		416 STAINLESS STEEL (HARDENED)	316 STAINLESS STEEL	R30006
ED	EAD			
1, 1-1/4, or 2 x 1	1	1U222546172	1U222535072	1U222539102
1-1/2 x 1	2 x 1	1U222046172	1U222035072	1U222039102
1-1/2 or 2-1/2 x 1-1/2	2 or 3 x 1-1/2	1U221946172	1U221935072	1U221939102
2 or 3 x 2	4 x 2	1U222646172	1U222635072	1U222639102
2-1/2 or 4 x 2-1/2	3 or 6 x 2-1/2	1U222746172	1U222735072	1U222739102
3	4	1U222846172	1U222835072	1U222839102
4	6	1U222946172	1U222933092	1U222939102
6	---	1U508046172	1U508033092	1U508039102
8	---	20A3260X012	20A3260X022	20A3260X152

Key 9* Fisher EAD Liner

LINER MATERIAL	VALVE SIZE, NPS	CL150 RF VALVE	CL300 RF VALVE	CL600 RF VALVE	SOCKET WELD VALVE	SCHEDULE 40 OR 80 BUTT WELD VALVE
416 stainless steel (hardened)	1	1V560146172	1U384246172	1V560246172	1V560146172	1V560146172
	2	1V560346172	1U384346172	1V560546172	1V560346172	1V560346172
	2 x 1	1V560646172	1U385146172	1V387646172	1V560646172	1V560646172
	3	2V561346172	2U384546172	2V561646172	---	2V561346172
	3 x 1-1/2	2V560946172	2U385346172	2V545946172	---	2V560946172
	4	2V562246172	2U384746172	2V561946172	---	2V562246172
	4 x 2	2V561846172	2U385546172	2V561246172	---	2V561846172
	6	2V563146172	2U384946172	2V562846172	---	2U384946172
6 x 2-1/2	2V562646172	2U385746172	2V562346172	---	2U385746172	
316 stainless steel	1	1V560135072	1U384235072	1V560235072	1V560135072	1V560135072
	2	1V560335072	1U384335072	1V560535072	1V560335072	1V560335072
	2 x 1	1V560635072	1U385135072	1V387635072	1V560635072	1V560635072
	3	2V561335072	2U384535072	2V561635072	---	2V561335072
	3 x 1-1/2	2V560935072	2U385335072	2V545935072	---	2V560935072
	4	2V562235072	2U384735072	2V561935072	---	2V562235072
	4 x 2	2V561835072	2U385535072	2V561235072	---	2V561835072
	6	2V563135072	2U384935072	2V562835072	---	2U384935072
6 x 2-1/2	2V562635072	2U385735072	2V562335072	---	2U385735072	

Key 9* Whisper Trim III Seat Ring (NPS 6 Fisher ED only)

410 SST	316 SST	316 SST w/ CoCr-A
21A9794X012	21A9794X022	21A9795X012

Gasket Descriptions

KEY NUMBER	DESCRIPTION	MATERIAL
		FGM -198° to 593° C (-325° to 1100° F)
10	Bonnet Gasket	Graphite/S31600
11	Cage Gasket	
13	Seat Ring or Liner Gasket	
14 or 20	Adapter Gasket	
12	Spiral-Wound Gasket	N06600/Graphite
27 or 51	Shim	S31600 (316 SST)

C-seal Parts for Fisher ED Valve (Keys 3*, 2*, 9*, 64*, 6*, and 7*)

VALVE SIZE	PORT DIA	TRAVEL	TRIM	STEM DIA	CHARACTERISTIC	CAGE	PLUG/RETAINER	SEAT RING	C-seal	PISTON RING	STEM											
NPS	Inch	Inch		mm (Inch)		Key 3	Key 2	Key 9	Key 64	Key 6	Key 7											
2-1/2 (ED) and 3 (EAD)	2.875	1.5	1	12.7 (1/2)	Linear	37B9140X012	27B2795X012	21B3687X012	24B3621X012	14B3620X012	1U3891X0102 ⁽³⁾ 10A8840XU22 ⁽⁴⁾											
					Equal %	37B3920X012																
					Whisper I	37B2792X012																
			37H	19.1 (3/4)	Linear	37B9140X012	27B4524X022	21B3687X012	24B3621X012	14B3620X012	1U3894X0022 ⁽³⁾ 1K5880X0262 ⁽⁴⁾											
					Equal %	37B3920X012																
					Whisper I	37B2792X012																
3 (ED) and 4 (EAD)	3.4375	1.5	1	12.7 (1/2)	Linear	34B5616X012	34B9832X012	23B6127X012	23B9196X012	13B9199X012	1K5869X0102 ⁽³⁾ 1U2306X0192 ⁽⁴⁾											
					Equal %	34B9857X012																
					Whisper I	37B2277X012																
				19.1 (3/4)	Linear	34B5616X012						34B9832X032	23B6127X012	23B9196X012	13B9199X012	1U3894X0022 ⁽³⁾ 1K5880X0262 ⁽⁴⁾						
					Equal %	34B9857X012																
					Whisper I	37B2277X012																
			37H	12.7 (1/2)	Linear	34B5616X012	34B5615X022	23B6127X022	23B9196X012	13B9199X012	1K5869X0102 ⁽³⁾ 1U2306X0192 ⁽⁴⁾											
					Equal %	34B9857X012																
					Whisper I	37B2277X012																
				19.1 (3/4)	Linear	34B5616X012						34B5615X012	23B6127X022	23B9196X012	13B9199X012	1U3894X0022 ⁽³⁾ 1K5880X0262 ⁽⁴⁾						
					Equal %	34B9857X012																
					Whisper I	37B2277X012																
4 (ED) and 6 (EAD)	4.375	2	1	12.7 (1/2)	Linear	34B5346X022	37B2279X012	23B6128X012	23B9197X012	14B5341X012	1U2305X0142 ⁽³⁾ 1U2306X0192 ⁽⁴⁾											
					Equal %	37B3194X012																
					Whisper I	34B9852X012																
				19.1 (3/4)	Linear	34B5346X022						37B2279X022	23B6128X012	23B9197X012	14B5341X012	1K5877X0132 ⁽³⁾ 1U4446X0102 ⁽⁴⁾						
					Equal %	37B3194X012																
					Whisper I	34B9852X012																
				25.4 (1)	Linear	34B5346X022											37B2279X032	23B6128X012	23B9197X012	14B5341X012	1K7796X0062 ⁽³⁾ 1K7891X0242 ⁽⁴⁾	
					Equal %	37B3194X012																
					Whisper I	34B9852X012																
				3H	12.7 (1/2)	Linear						34B5346X012	34B5345X032	23B6128X022	23B9197X012	14B5341X012						1U2305X0142 ⁽³⁾ 1U2306X0192 ⁽⁴⁾
						Equal %						37B3194X022										
						Whisper I						---										
			19.1 (3/4)		Linear	34B5346X012	34B5345X012	23B6128X022	23B9197X012	14B5341X012	1K5877X0132 ⁽³⁾ 1U4446X0102 ⁽⁴⁾											
					Equal %	37B3194X022																
					Whisper I	---																
			25.4 (1)	Linear	34B5346X012	34B5345X022						23B6128X022	23B9197X012	14B5341X012	1K7796X0062 ⁽³⁾ 1K7891X0242 ⁽⁴⁾							
				Equal %	37B3194X022																	
				Whisper I	---																	
			37H	12.7 (1/2)	Linear		34B5346X022	34B5345X032	23B6128X022	23B9197X012	14B5341X012					1U2305X0142 ⁽³⁾ 1U2306X0192 ⁽⁴⁾						
					Equal %		37B3194X012															
					Whisper I		34B9852X012															
				19.1 (3/4)	Linear	34B5346X022	34B5345X012					23B6128X022	23B9197X012	14B5341X012	1K5877X0132 ⁽³⁾ 1U4446X0102 ⁽⁴⁾							
					Equal %	37B3194X012																
					Whisper I	34B9852X012																
25.4 (1)	Linear	34B5346X022		34B5345X022	23B6128X022	23B9197X012											14B5341X012	1K7796X0062 ⁽³⁾ 1K7891X0242 ⁽⁴⁾				
	Equal %	37B3194X012																				
	Whisper I	34B9852X012																				
4 (ED)	4.375	2					37H					19.1 (3/4)	Cavitrol III 1-Stage	34B1847X012	34B8993X012				24B8994X012	23B9197X012	14B5341X012	1K5877X0132 ⁽³⁾
													Cavitrol III 2-Stage	34B8990X012	24B8988X032				24B8995X012	24B3621X012	14B3620X012 (2 req'd)	(1)(3)
	2.875	4					76					19.1 (3/4)										

1. Plug/retainer/stem assembly used.
 2. Requires bonnet spacer 34B9846X012.
 3. For Standard Bonnet.
 4. For Style 1 Extension Bonnet.
 5. Requires bonnet spacer 34B1369X012.

-continued-

C-seal Parts for Fisher ED Valve (Keys 3*, 2*, 9*, 64*, 6*, and 7*) (continued)

VALVE SIZE	PORT DIA	TRAVEL	TRIM	STEM DIA	CHARACTER-ISTIC	CAGE	PLUG/RETAINER	SEAT RING	C-seal	PISTON RING	STEM				
NPS	Inch	Inch		mm (Inch)		Key 3	Key 2	Key 9	Key 64	Key 6	Key 7				
6 (ED)	7	2	1	19.1 (3/4)	Linear	33B9178X012	33B9195X012	29A9703X012	23B9182X012	13B9176X012	1K5877X0132 ⁽³⁾ 1U4446X0102 ⁽⁴⁾				
					Equal %	34B3628X012									
					Whisper I	34B9828X022									
			3H	25.4 (1)	Linear	33B9178X012	33B9195X022	29A9703X012	23B9182X012	13B9176X012	1N7047X0052 ⁽³⁾ 1L8776X0032 ⁽⁴⁾				
					Equal %	34B3628X012									
					Whisper I	34B9828X022									
		37H	19.1 (3/4)	Linear	33B9178X022	34B7699X022	29A9703X022	23B9182X012	13B9176X012	1K5877X0132 ⁽³⁾ 1U4446X0102 ⁽⁴⁾					
				Equal %	34B3628X022										
				Whisper I	34B9828X012										
		37H	25.4 (1)	Linear	33B9178X022	34B7699X012	29A9703X022	23B9182X012	13B9176X012	1N7047X0052 ⁽³⁾ 1L8776X0032 ⁽⁴⁾					
				Equal %	34B3628X022										
				Whisper I	34B9828X012										
	5.375	4	76	25.4 (1)	Cavitrol III 2-Stage	33B9185X012	37B1413X0A2	24B9858X012	24B2191X012	13B9186X012 (2 req'd)	(1) ⁽³⁾				
					8 (ED)	3	1	19.1 (3/4)	Linear	37B1663X022	37B6392X022	29A9704X012	34B9827X012	24B9826X012	1K5880X0262 ⁽³⁾
									Equal %	37B5635X022					
									Whisper I	37B1663X022					
							3H	25.4 (1)	Linear	37B1663X022	37B6392X012	29A9704X012	34B9827X012	24B9826X012	10A3282X222 ⁽⁴⁾
									Equal %	37B5635X022					
Whisper I	37B1663X022														
37H	31.8 (1-1/4)	Linear	37B1663X022	---		29A9704X012	34B9827X012	24B9826X012	1L2298X0202 ⁽⁴⁾						
		Equal %	37B5635X022												
		Whisper I	47B6378X012												
2	3.5 ⁽⁵⁾	1	25.4 (1)	Whisper I		47B6378X012	37B6389X012	29A9704X012	34B9827X012	24B9826X012	10A3282X222 ⁽⁴⁾				
				Whisper I		47B5214X012									
				Whisper I		47B6378X012									
2	3.5 ⁽⁵⁾	3H	31.8 (1-1/4)	Whisper I	47B6378X012	37B6379X012	29A9704X012	34B9827X012	24B9826X012	10A6073X072 ⁽⁴⁾					
				Whisper I	47B5214X012										
				Whisper I	---										
3	8	3H	19.1 (3/4)	Linear	37B1663X012	37B1665X032	29A9704X022	34B9827X012	24B9826X012	1K5880X0262 ⁽³⁾					
				Equal %	37B5635X012										
				Whisper I	37B1663X012										
		37H	25.4 (1)	Linear	37B1663X012	37B1665X012	29A9704X022	34B9827X012	24B9826X012	10A3282X222 ⁽⁴⁾					
				Equal %	37B5635X012										
				Whisper I	37B1663X022										
2	3.5 ⁽⁵⁾	37H	31.8 (1-1/4)	Linear	37B1663X022	37B1665X022	29A9704X012	34B9827X012	24B9826X012	1L2298X0202 ⁽⁴⁾					
				Equal %	37B5635X022										
				Whisper I	---										
3	8	37H	19.1 (3/4)	Linear	37B1663X022	37B1665X032	29A9704X022	34B9827X012	24B9826X012	1K5880X0262 ⁽³⁾					
				Equal %	37B5635X022										
				Whisper I	37B1663X022										
2	3.5 ⁽⁵⁾	37H	25.4 (1)	Whisper I	47B6378X012	34B9848X012	29A9704X012	34B9827X012	24B9826X012	10A3282X222 ⁽⁴⁾					
				Whisper I	47B5214X012										
				Whisper I	47B6378X012										
2	3.5 ⁽⁵⁾	37H	31.8 (1-1/4)	Whisper I	47B6378X012	---	29A9704X012	34B9827X012	24B9826X012	10A6073X072 ⁽⁴⁾					
				Whisper I	47B5214X012										
				Whisper I	---										
8 (ED)	8	4 ⁽²⁾	318	25.4 (1)	Whisper III-A1	44B9847X012	34B9848X012	29A9704X022	34B9827X012	24B9826X012	10A3282X222 ⁽⁴⁾				

1. Plug/retainer/stem assembly used.
 2. Requires bonnet spacer 34B9846X012.
 3. For Standard Bonnet.
 4. For Style 1 Extension Bonnet.
 5. Requires bonnet spacer 34B1369X012.

Keys 10*, 11*, 12*, 13*, 14*, 20*, 27*, and 51* Gaskets and Shims

Valve Size, NPS		Standard Trim Cage Whisper Trim I Cage Cavitrol III - 1 Stage Cage		Cavitrol III - 2 Stage Cage Whisper Trim III Cage WhisperFlo Cage		VALVE SIZE, NPS		Standard Trim Cage Whisper Trim I Cage Cavitrol III - 1 Stage Cage		Cavitrol III - 2 Stage Cage Whisper Trim III Cage WhisperFlo Cage	
ED	EAD	Key Number	-198 to 593°C (-325 to 1100°F)	Key Number	-198 to 593°C (-325 to 1100°F)	ED	EAD	Key Number	-198 to 593°C (-325 to 1100°F)	Key Number	-198 to 593°C (-325 to 1100°F)
1 or 1-1/4	1	Set ⁽¹⁾ 10 12 13 27 or 51	RGASKETX162 1R2859X0042 1R286099442 1R2862X0062 16A1936X012	Set 10 12 13 51	RGASKETX422 1R2859X0042(qty 2) 1R286099442 1R2862X0062 16A1936X012	3	4	Set ⁽¹⁾ 10 12 13 27 or 51	RGASKETX202 1R3484X0042 1R348299442 1R3481X0052 16A1940X012	Set 10 12 13 51	RGASKETX462 1R3484X0042(qty 2) 1R348299442 1R3481X0052 16A1940X012
1-1/2	2	Set ⁽¹⁾ 10 12 13 27 or 51	RGASKETX172 1R3101X0032 1R309999442 1R3098X0052 16A1937X012	Set 10 12 13 51	RGASKETX432 1R3101X0032(qty 2) 1R309999442 1R3098X0052 16A1937X012	3 x 2	4 x 2	Set ⁽¹⁾ 10 11 12 13 14 27 or 51	RGASKETX272 1R3484X0042 1R3298X0032 1R329799442 1R3296X0042 1R3481X0052 16A1938X012	---	---
1-1/2 x 1	2 x 1	Set ⁽¹⁾ 10 11 12 13 20 27 or 51	RGASKETX242 1R3101X0032 1R2861X0042 1R286099442 1R3098X0052 1U2152X0042 16A1936X012	---	---	4	6	Set ⁽¹⁾ 10 12 13 27 or 51	RGASKETX212 1R3724X0042 1R372299442 1J5047X0062 16A1941X012	Set 10 12 13 51	RGASKETX472 1R3724X0042(qty 2) 1R372299442 1J5047X0062 16A1941X012
2	---	Set 10 12 13 51	RGASKETX182 1R3299X0042 1R329799442 1R3296X0042 16A1938X012	Set 10 12 13 51	RGASKETX442 1R3299X0042(qty 2) 1R329799442 1R3296X0042 16A1938X012	4 x 2-1/2	6 x 2-1/2	Set ⁽¹⁾ 10 11 12 13 14 27 or 51	RGASKETX282 1R3724X0042 1R3846X0042 1R384599442 1R3844X0052 1J5047X0062 16A1939X012	---	---
2 x 1	---	Set 10 11 12 13 14 51	RGASKETX252 1R3299X0042 1R2861X0042 1R286099442 1R2862X0062 1R3296X0042 16A1936X012	---	---	6	---	Set 10 12 13 51	RGASKETX222 1U5081X0052 1U508599442 1U5086X0032 16A1942X012	Set 10 12 13 51	RGASKETX482 1U5081X0052(qty 2) 1U508599442 1U5086X0032 16A1942X012
2-1/2	3	Set ⁽¹⁾ 10 12 13 27 or 51	RGASKETX192 1R3847X0032 1R384599442 1R3844X0052 16A1939X012	Set 10 12 13 51	RGASKETX452 1R3847X0032(qty 2) 1R384599442 1R3844X0052 16A1939X012	8	---	Set 10 13	RGASKETX232 10A3265X112 10A3266X082	Set 10 13	10A3265X152 10A3265X112(qty 2) 10A3266X082
2-1/2 x 1-1/2	3 x 1-1/2	Set ⁽¹⁾ 10 11 12 13 14 27 or 51	RGASKETX262 1R3847X0032 1R3100X0032 1R309999442 1R3098X0052 1R3844X0052 16A1937X012	---	---						

1. Set number good for both ED and EAD valve.

Actuator Groups (by Type Number)

Group 1 54 mm (2-1/8 inches), 71 mm (2-13/16 inches) or 90 mm (3-9/16 inches) Yoke Boss	Group 100 127 mm (5 inches) Yoke Boss	Group 403 90.5 mm (3-9/16 inches) Yoke Boss
585C 1B 644 & 645 655 657 & 667—76.2 mm (3 inches) travel 1008—71.4 mm (2-13/16 inches) yoke boss	585C 657 1008 Group 101 127 mm (5 inches) Yoke Boss 667	585C 1008

Figure 19. Standard NPS 1 through 6 Fisher ED and EAD Valves

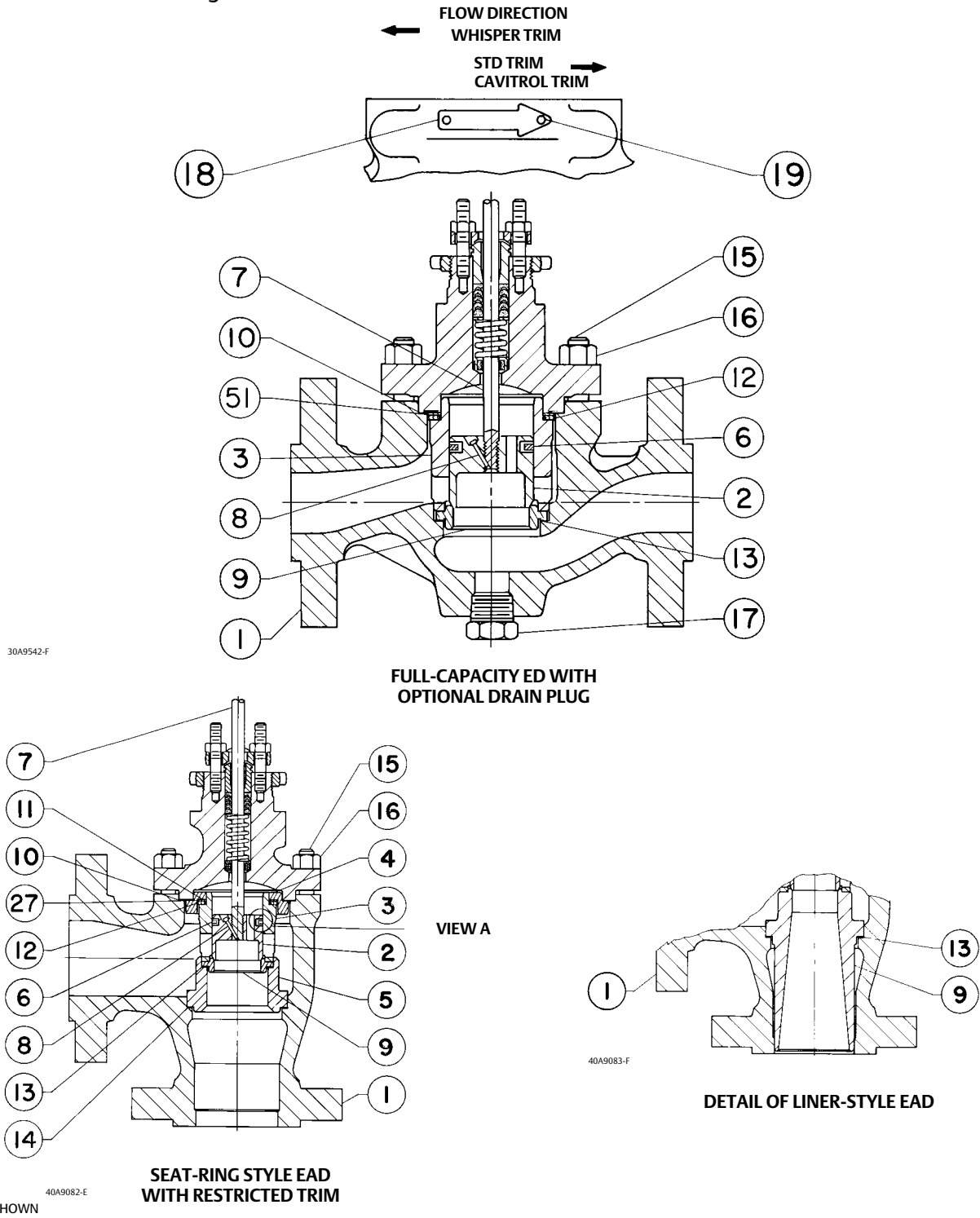

Figure 20. Whisper Trim III Detail with Optional Drain Plug

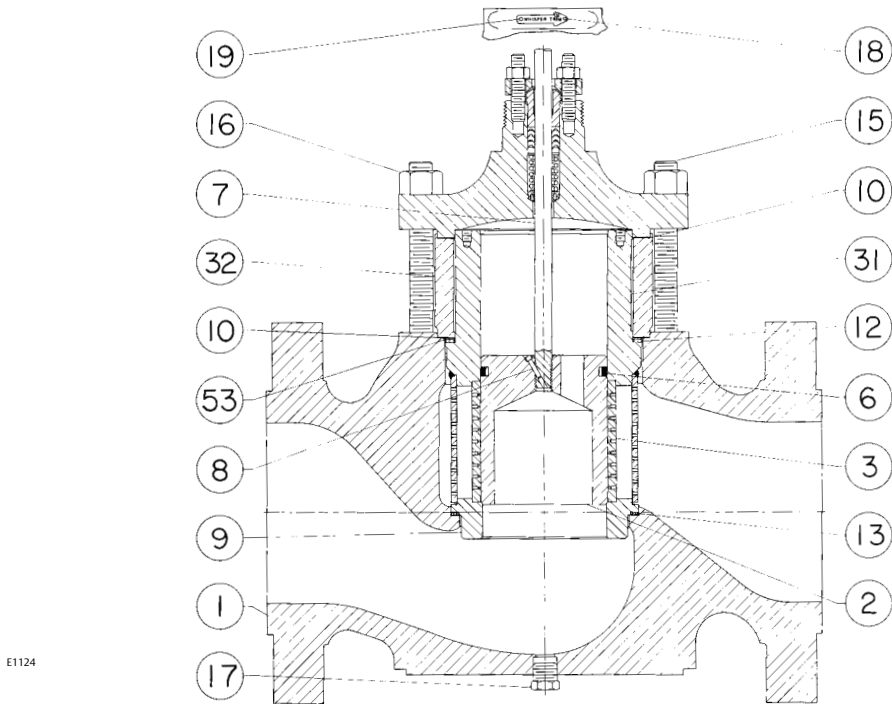

Figure 21. NPS 8 Fisher ED Valve with Graphite Piston Ring and Optional Drain Plug

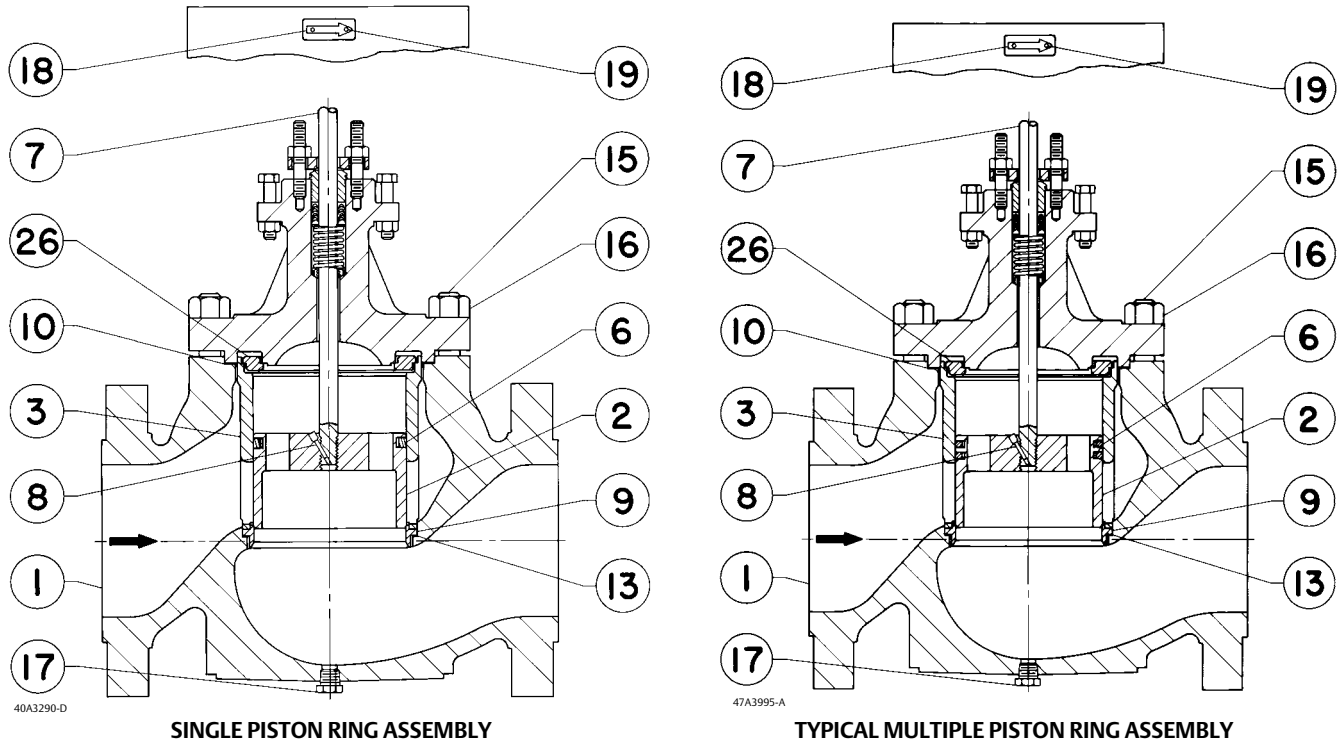
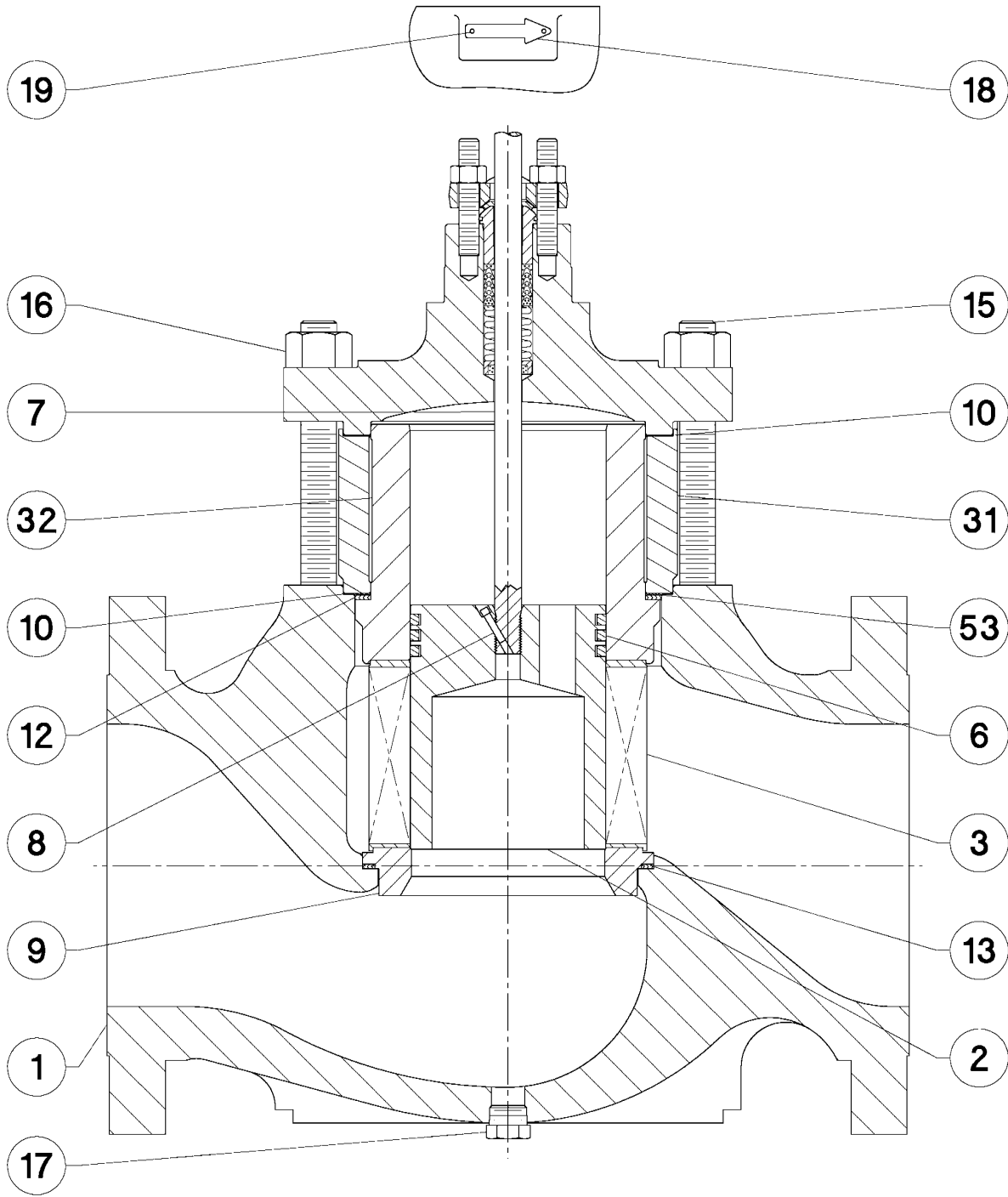
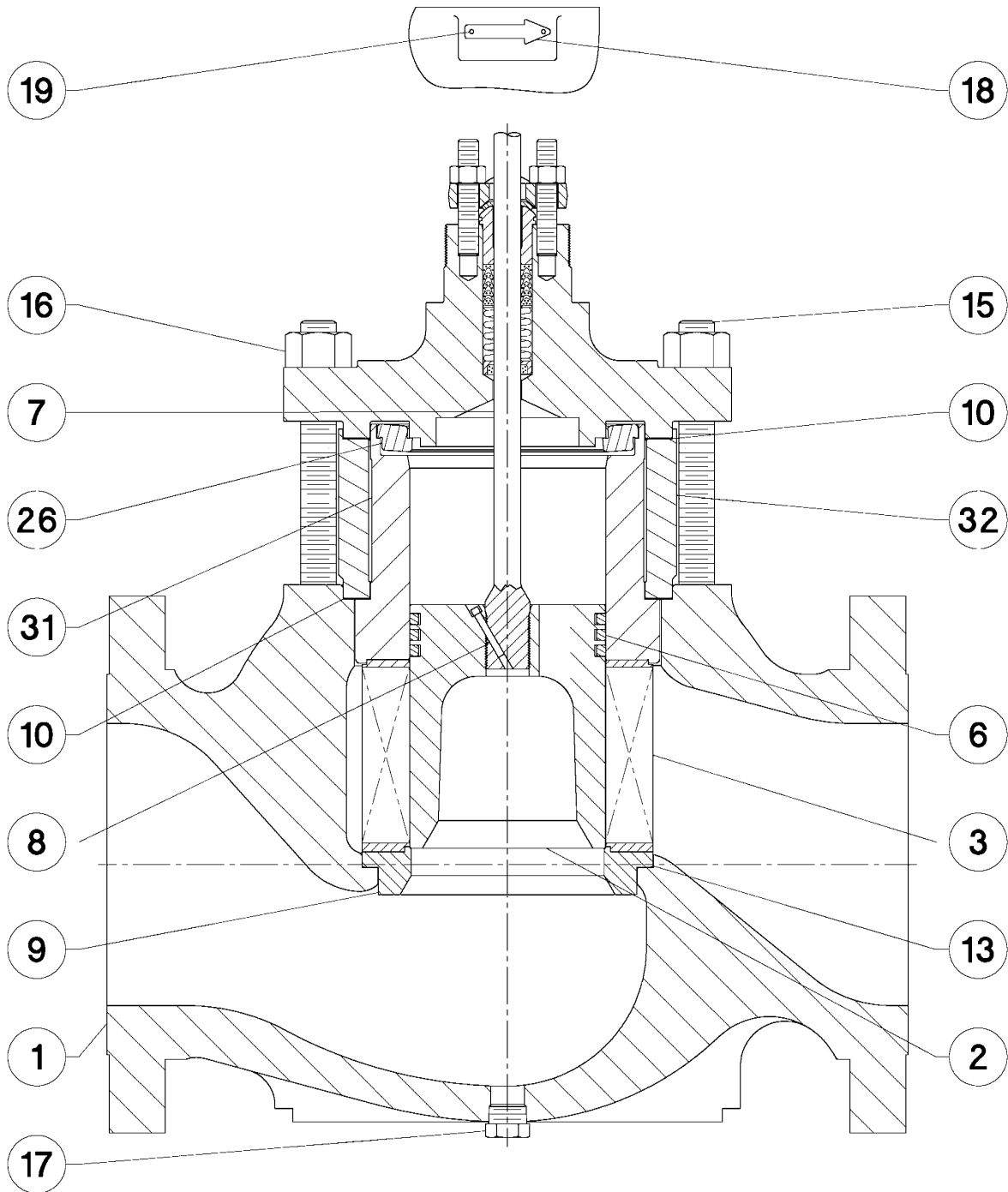

Figure 22. Fisher ED Valve Assembly with WhisperFlo Cage and Optional Drain Plug



E1125

Figure 23. NPS 8 Fisher ED Valve Assembly with WhisperFlo Cage and Optional Drain Plug



E1123

Figure 24. Gasket Set Detail with Optional Drain Plug

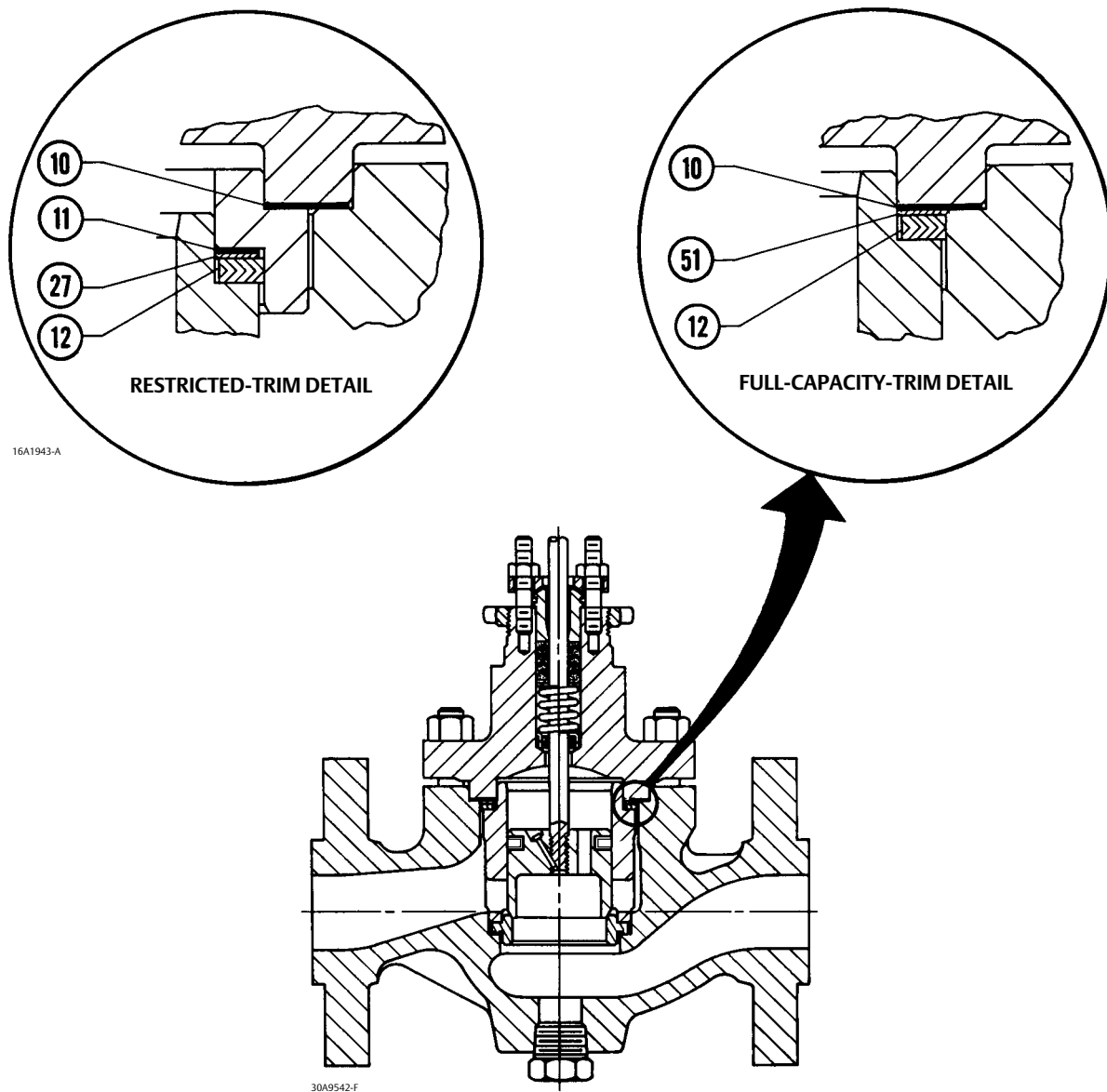

Neither Emerson, Emerson Automation Solutions, nor any of their affiliated entities assumes responsibility for the selection, use or maintenance of any product. Responsibility for proper selection, use, and maintenance of any product remains solely with the purchaser and end user.

Fisher, ENVIRO-SEAL, Cavitrol, easy-e, WhisperFlo, and Whisper Trim are marks owned by one of the companies in the Emerson Automation Solutions business unit of Emerson Electric Co. Emerson Automation Solutions, Emerson, and the Emerson logo are trademarks and service marks of Emerson Electric Co. All other marks are the property of their respective owners.

The contents of this publication are presented for informational purposes only, and while every effort has been made to ensure their accuracy, they are not to be construed as warranties or guarantees, express or implied, regarding the products or services described herein or their use or applicability. All sales are governed by our terms and conditions, which are available upon request. We reserve the right to modify or improve the designs or specifications of such products at any time without notice.

Emerson Automation Solutions
Marshalltown, Iowa 50158 USA
Sorocaba, 18087 Brazil
Cernay 68700 France
Dubai, United Arab Emirates
Singapore 128461 Singapore

www.Fisher.com

